

# MPT-3000V

## In-Vehicle System

E-Mark Certified Intel® Atom™ Processor E3845  
In-Vehicle Fanless Box PC with WWAN Redundancy



## Specifications

|                          |   |
|--------------------------|---|
| System Mainboard         | MBT-3001V   |
| CPU Type                 | Intel® Atom™ Processor E3845  |
| System Speed             | 1.91GHz   |
| Memory                   | 2x 2GB DDR3L-1333 SO-DIMM (Dual Channel)  |
| Construction             | Aluminum  |
| Chassis Color            | Black   |
| Front Panel External I/O | CFAST, 2.5" device bay, 2nd Mic-In & Line-Out<br>2x SIM sockets, 1x USB 3.0, 1x USB 2.0, Reset button,<br>Status LEDs, 4x antenna connectors  |
| Rear Panel External I/O  | DVI-D, VGA, 3x COMs (one with RS422/485 options)<br>2x GbE, 2x USB 2.0, power connection<br>1st Mic-In & Line-Out, GPIO, GbE status LEDs  |
| Storage                  | 2.5" device bay for SSD & HDD   |
| Expansion slots          | 1x Half size Mini PCI-E socket (USB 2.0)<br>1x Full size Mini PCI-E socket (USB 2.0 + PCI-E)<br>1x 2230 Socket 1 M.2 socket (USB 2.0 + PCI-E)<br>1x 3042 Socket 2 WWAN M.2 socket (USB 2.0)<br>1x 2280 Socket 3 SSD M.2 socket (SATA) |
| Power Supply             | DC 9V~36V   |
| Mounting                 | Custom mounting rail  |
| Dimensions               | 256.0 (W) x 182.0 (D) x 55.0 (H) mm<br>10.08" (W) x 7.17" (D) x 2.16" (H)   |
| Operating Temperature    | SSD: -40°C ~ 70°C (-40°F~158°F)<br>HDD: -20°C ~ 50°C (-4°F~122°F)   |
| Storage Temperature      | -40°C ~ 85°C (-40°F~185°F)  |
| Relative Humidity        | 10 ~ 95% RH @ 45°C (non-condensing)   |
| Vibration                | Operating/Non-operating (SSD): 2,26 Grms (5~500 Hz) /<br>MIL-STD-810G composite wheeled condition (Z-axis only)<br>Operating/Non-operating (HDD): 1,04 Grms (5~500 Hz) /<br>MIL-STD-810G highway truck condition (Z-axis only)        |
| Shock                    | Non-operating: Sawtooth: 40G, 11 msec (Z-axis)<br>Operating: Sawtooth: 20G, 11msec (Z-axis)   |
| Certification            | E-Mark, CE class B, FCC class B   |

## Features

- Fanless design
- Dual SIM sockets support WWAN redundancy
- Removable 2.5" device bay and CFAST socket
- Rich I/O interfaces for wireless, SSD, GPS, WWAN and add-on card expansion
- Fully car battery power control
- Wide-range voltage GPIO interface
- Optional CAN 2.0B/ OBD-II function (SAE J1939)

## Ordering Information

|                |   |
|----------------|---|
| MPT-3000VSM    | MPT-3000V with MBT-3001V, Intel® Atom™ Processor E3845 w/ 2x 2GB DDR3L-1333, SSD bay, No PSU, No storage (RoHS) |
| LTE-ANT-INT-1  | 20CM 4G/3G WWAN antenna cable from M.2 to SMA Jack  |
| LTE-ANT-INT-2  | 20CM 4G/3G WWAN antenna cable from mPCIe to SMA Jack  |
| WLAN-ANT-INT-1 | 20CM WLAN antenna cable from M.2 to SMA Jack  |

## Dimensions

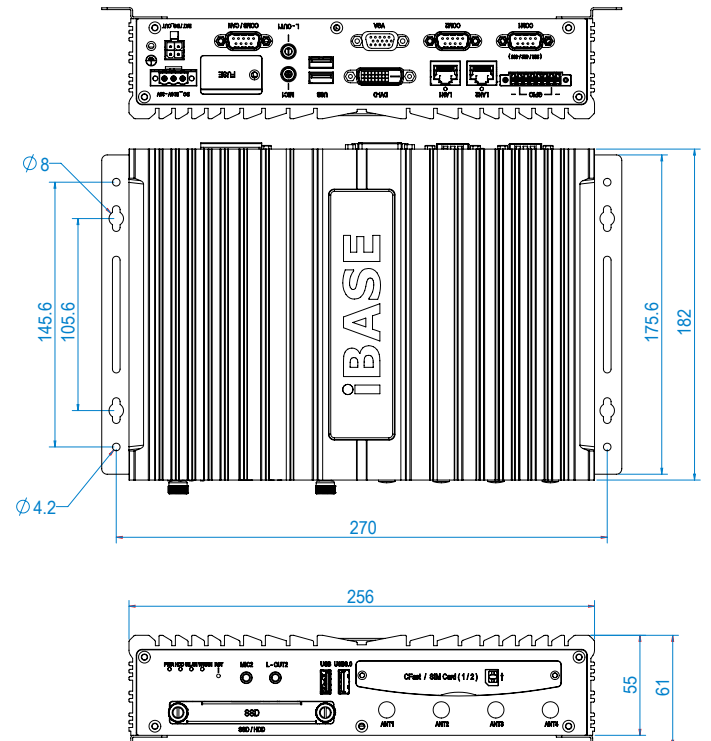

Remarks: 1. Specifications are subject to change without prior notice. 2. ODM/OEM is available. 3. For user's manual & datasheet download, visit [www.ibase.com.tw](http://www.ibase.com.tw).