



一众显示科技有限公司

TEAM SOURCE DISPLAY TECH. CO, LTD.

TFT-LCD Module Specification

Module NO.: TST123HDKK-06C

Version: V1.2

APPROVAL FOR SPECIFICATION

APPROVAL FOR SAMPLE

For Customer' s Acceptance:	
Approved by	Comment

Team Source Display:		
Presented by	Reviewed by	Organized by

Version No.	Date	Content	Remark
V1.0	2022-09-26	Initial Release	
V1.1	2022-10-25	Modify surface luminance	
V1.2	2023-01-02	Modify AR+AF Lens	

CONTENTS

1 GENERAL CHARACTERISTICS - 3 -

2 PRODUCT DRAWINGS - 4 -

3 INTERFACE DESCRIPTION - 5 -

4 LVDS 错误! 未定义书签。

5 ABSOLUTE MAXIMUM RATINGS - 11 -

6 ELECTRICAL CHARACTERISTICS - 11 -

7 BACKLIGHT CHARACTERISTICS 错误! 未定义书签。

8 LCD OPTICAL SPECIFICATIONS - 11 -

9 TOUCH PANEL SPECIFICATIONS - 14 -

 9.1 MECHANICAL CHARACTERISTICS - 14 -

 9.2 ELECTRICAL CHARACTERISTICS - 14 -

 9.3 INTERFACE TIMING CHARACTERISTICS - 14 -

10 RELIABILITY TEST - 15 -

11 IMAGE STICKING - 15 -

 11.1 WHAT IS IMAGE STICKING? - 15 -

 11.2 WHAT CAUSE IMAGE STICKING? - 16 -

 11.3 HOW TO AVOID IMAGE STICKING? - 16 -

 11.4 HOW TO FIX THE IMAGE STICKING? - 16 -

 11.5 IS IMAGE STICKING COVERED BY TSD WARRANTY? - 17 -

 11.6 OTHERS - 17 -

12 SUGGESTIONS FOR USING LCD MODULES - 17 -

 12.1 HANDLING OF LCM - 17 -

 12.2 STORAGE - 18 -

13 LIMITED WARRANTY - 18 -

 13.1 - 18 -

 13.2 - 18 -

 13.3 - 18 -

1 General Characteristics

ITEM	Specification	Unit
LCD Type	a-Si TFT, Transmissive, Normally black, IPS	-
LCD Size	12.3	inch
Resolution (W x H)	1920x (RGB) × 720	pixel
LCM size	302.59(H) x 123.57(V) x 6.51(T)	mm
Active Area	292.03 (H) x 109.51 (V)	mm
Pixel pitch	0.1521(H) × 0.1521(V)	mm
Viewing Direction	ALL o'clock	-
Color Depth	16.7M	-
Pixel Arrangement	RGB-stripe	-
Backlight Type	36 leds, 360mA, 27V	-
Surface Luminance	800~960TYP	cd/m ²
Surface Treatment	-	-
LCD Driver IC	-	-
Interface Type	LVDS	-
Input Voltage	3.3	V
With/Without TP	With CTP(IC:ILI2511)	-
Weight	TBD	g

Note 1: RoHS compliant

Note 2: LCM weight tolerance: ± 5%.

2 Product drawings

AF+AR Coating
 12.3" A11 O'clock
 1320(RGB)720
 Screen printing black

CTP T=3.90±0.4
 LCM 6.51±0.2
 3.00±0.2 (Lens)
 0.70±0.05 (Sensor)
 0.20±0.05 (OCA)
 3M Tape
 304J05 T=0.175mm
 13.51
 15.41
 123.57±0.5 (LCM OD)
 302.59±0.5 (LCM OD)
 13.71±0.1
 15.41
 125.04±0.1 (Sensor OD)
 3M Tape
 SUS T=0.2mm
 30°

BL 电路图
 A1
 A2
 A3

NTC 电路图
 NTC
 100±0.03
 0.50±0.03
 2.50±0.05
 0.30±0.1
 3.50±0.1
 DETAIL "A" (4:1)

CTP specifications:
 1. COVER GLASS-SENSOR GLASS+FFC
 COVER GLASS:3.0mm
 SENSOR GLASS:0.7mm
 IC: ILI2511
 Resolution:1920(RGB)*720
 2. Voltage:2.8~3.3V
 3. Transmittance: ≥88%
 4. Surface hardness: 6H
 5. Tem.op:-30°C~+85°C, ≤85RH
 6. Tem.st:-40°C~+90°C, ≤90RH

LCM PIN DESCRIPTION					
PIN	NAME	PIN	NAME	PIN	NAME
1	GND	16	ORCLKIN-	31	FAULT
2	BIST	17	ORCLKIN+	32	RESET
3	VCC	18	DRXIN3-	33	STBYB
4	VCC	19	DRXIN3+	34	CSB
5	GND	20	ERXIN0-	35	SCL
6	GND	21	ERXIN0+	36	SDAI
7	OTP	22	ERXIN1-	37	SDAO
8	NC	23	ERXIN1+	38	GND
9	GND	24	ERXIN2-	39	GND
10	DRXIN0-	25	ERXIN2+	40	NC
11	DRXIN0+	26	FRCLKIN-	41	LEDA
12	DRXIN1-	27	FRCLKIN+	42	LEDA
13	DRXIN1+	28	FRXIN3-	43	LEDA
14	DRXIN2-	29	FRXIN3+	44	NC
15	DRXIN2+	30	GND	45	LEDPK

CTP I/P

PIN NO	DIRECTION
1	GND
2	INT
3	INT
4	SDAI(0.3V)
5	SCL(0.3V)
6	VDD(0.3V)

NOTES:
 1. GENERAL TOLERANCE: ±0.3
 2. () REFERENCE DIMENSION
 3. Important dimension: ①②③

变更记录 (Revise history)

版本 (version)	日期 (Date)	设计 (DESIGN)	审核 (CHECKED)	批准 (APPROVED)	客户承认 (CUSTOMER APPROVAL)
A0	2022.07.30	设计 (DESIGN)	Bill	Aron	
A1	2022.08.01	审核 (CHECKED)	Aron		
A2	2022.08.08	批准 (APPROVED)	Aron		
A3	2022.10.25				
A4	2023.01.02				

12.3" TFT Transmissive
 Normally black, PS
 1920(RGB)720
 All color
 16:9
 3.3V
 with CTP(0.5V)
 36 LEDs, 36mA(Ap), 27V(Vel)
 800~960 cd/m²
 -30°C~85°C
 1000000h @ 25°C, 2500

TEAM SOURCE DISPLAY
 TSD
 TITLE: LCM+CTP
 Drawing No. TST123HDKK-06C
 页面 (Page) 1 / 1
 单位 (Unit) mm
 比例 (SCALE) 1 : 1
 角度 (Ang.) 0°

3 Interface description

NO.	Symbol	Functions
1	GND	Digital ground
2	BIST	LCD Panel Self Test Enable, When it is not used, connecting to GND is recommended, don't floating
3	VCC	Digital Power/Vin = 3.3V
4	VCC	Digital Power/Vin = 3.3V
5	GND	Digital ground
6	GND	Digital ground
7	OTP	Serial interface OTP power
8	NC	No connector
9	GND	Digital ground
10	ORXIN0-	Negative LVDS differential data input(Odd data)
11	ORXIN0+	Positive LVDS differential data input(Odd data)
12	ORXIN1-	Negative LVDS differential data input(Odd data)
13	ORXIN1+	Positive LVDS differential data input(Odd data)
14	ORXIN2-	Negative LVDS differential data input(Odd data)
15	ORXIN2+	Positive LVDS differential data input(Odd data)
16	ORXCLKIN-	Negative LVDS differential data input(Odd clock)
17	ORXCLKIN+	Positive LVDS differential data input(Odd clock)
18	ORXIN3-	Negative LVDS differential data input(Odd data)
19	ORXIN3+	Positive LVDS differential data input(Odd data)
20	ERXIN0-	Negative LVDS differential data input(Even data)
21	ERXIN0+	Positive LVDS differential data input(Even data)
22	ERXIN1-	Negative LVDS differential data input(Even data)
23	ERXIN1+	Positive LVDS differential data input(Even data)
24	ERXIN2-	Negative LVDS differential data input(Even data)
25	ERXIN2+	Positive LVDS differential data input(Even data)

NO.	Symbol	Functions
26	ERXCLKIN-	Negative LVDS differential data input(Even clock)
27	ERXCLKIN+	Positive LVDS differential data input(Even clock)
28	ERXIN3-	Negative LVDS differential data input(Even data)
29	ERXIN3+	Positive LVDS differential data input(Even data)
30	GND	Digital ground
31	FAULT	FAULT signal output(normal=H, abnormal=L)
32	RESET	Global reset pin, active High
33	STBYB	Standby mode, active High
34	CSB	Serial interface chip enable
35	SCL	Serial interface clock input
36	SDAI	Serial interface data input
37	SDAO	Serial interface data output
38	GND	Digital ground
39	GND	Digital ground
40	NC	No connector
41	LEDA	LED power(Anode)
42	LEDA	LED power(Anode)
43	LEDA	LED power(Anode)
44	NC	No connector
45	LEDK	Cathode1
46	LEDK	Cathode2
47	LEDK	Cathode3
48	LEDK	Cathode4
49	NTC_A	NTC_Anode
50	NTC_K	NTC_Cathode

4 Signal Timing Specification

Parameter	Symbols	Panel Resolution			Unit
		1920RGB*720 (2 port)			
		Min.	Typ.	Max.	
DCLK frequency	Fddk	-	45.3	-	MHz
Horizontal valid data	Thd	-	960	-	DCLK
1 horizontal line	Th	1015	1026	1248	DCLK
Vertical valid data	Tvd	-	720	-	H
1 vertical field	Tv	730	736	756	H
Frame rate	FR	-	60	-	Hz

1.1 Signal Electrical Characteristics for LVDS Receiver

The built-in LVDS receiver is compatible with (ANSI/TIA/TIA-644) standard.

Parameter	Symbol	Condition	Specification			Unit
			Min.	Typ.	Max.	
Differential input high Threshold voltage	V _{th}	V _{cm} = 1.2V	0.1	-	-	
Differential input low Threshold voltage	V _{tl}	V _{cm} = 1.2V	-	-	0.1	
Differential input common Mode voltage	V _{CM}	-	1	1.2	1.7 - V _{id} / 2	
LVDS input voltage	V _{INLV}	-	0.7	-	1.7	
Differential input voltage	V _{id}	-	0.1	-	0.6	
Differential input leakage current	I _{vleak}	-	-10	-	10	

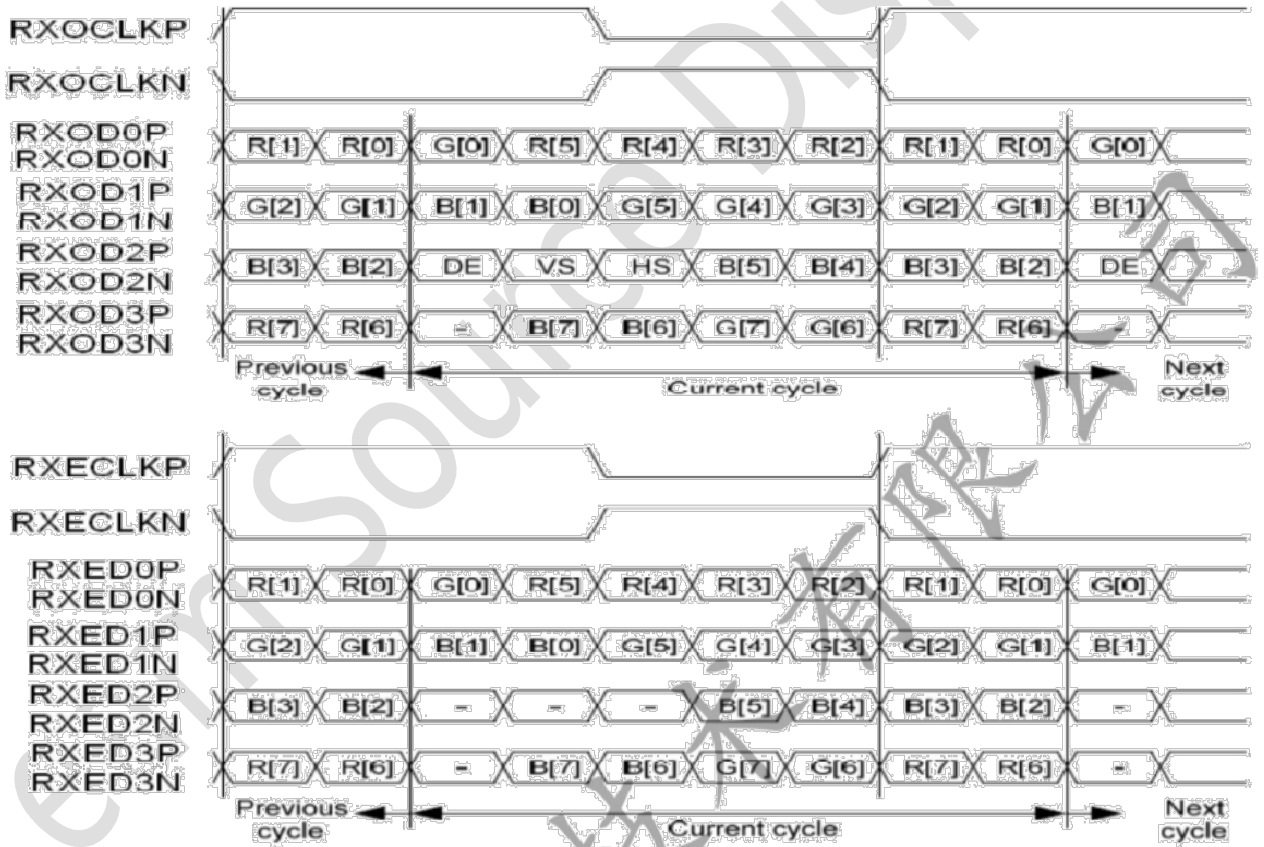
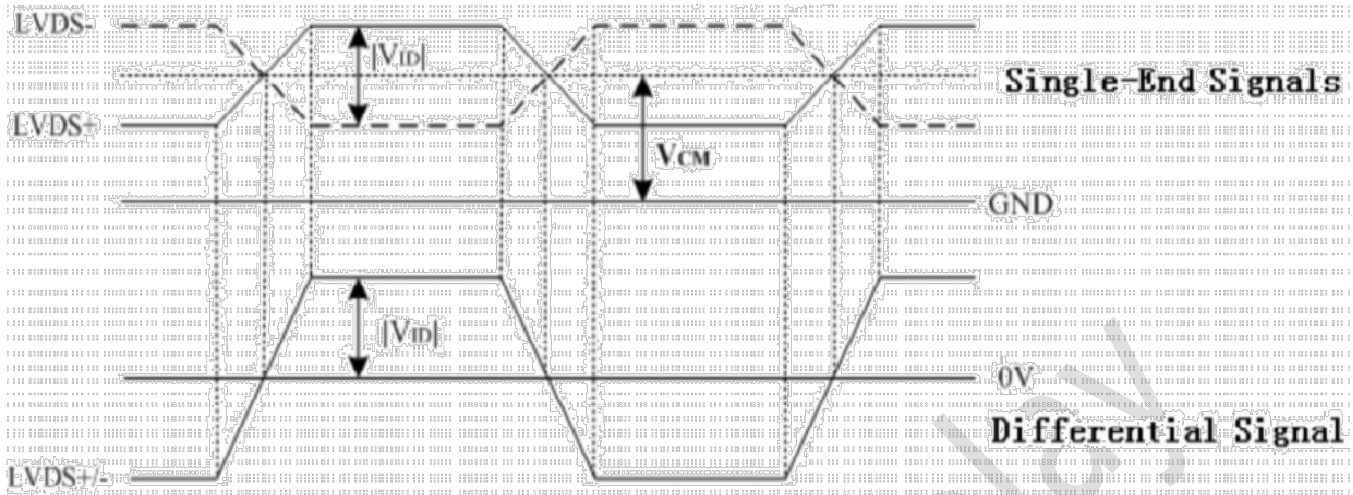

1.2

POWER SEQUENCE

prevent a latch-up or DC operation of the LCD module, the power on/off sequence shall be as shown in below.

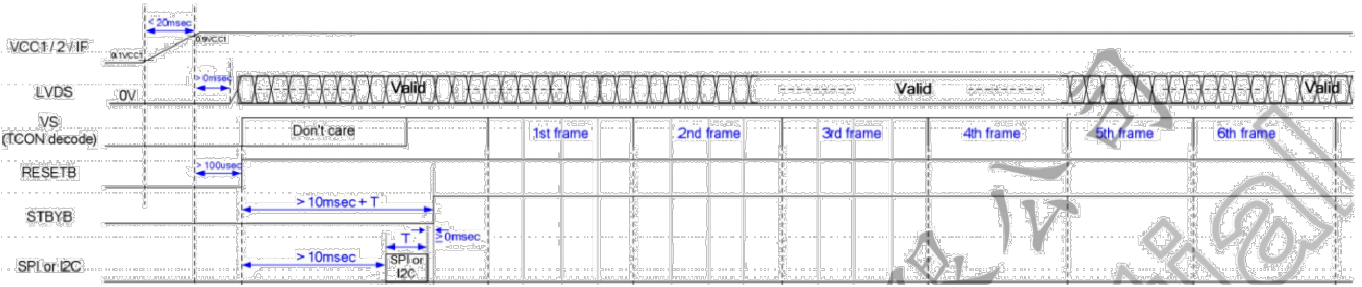

Power-on Sequence

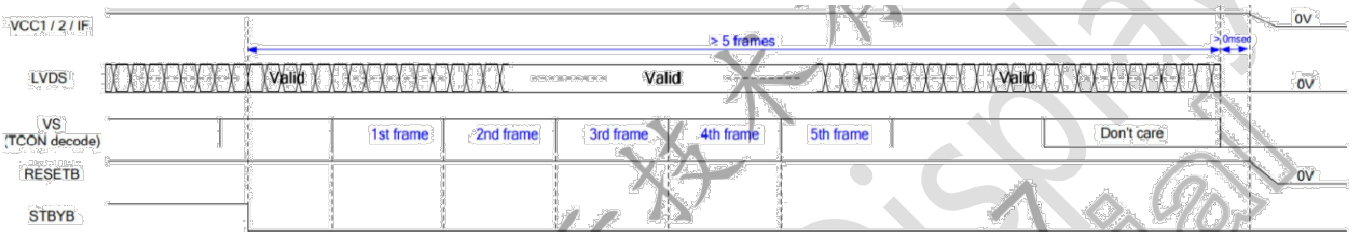

Power-off Sequence

1.3 DC Characteristics Backlight Driving

Parameter	Symbol	Min	Typ	Max	Units	Condition
LED Current	I_F	-	360	-	mA	$T_a=25^\circ\text{C}$
LED Voltage	V_F	24.3	27	30.6	Volt	$T_a=25^\circ\text{C}$
LED Life-Time	N/A	30000	--	--	Hour	$T_a=25^\circ\text{C}$ $I_F=90\text{mA}$

Note (1) LED life time (Hr) can be defined as the time in which it continues to operate under the condition: $T_a=25\pm3\text{ }^\circ\text{C}$, typical IL value indicated in the above table until the brightness becomes less than 50%.

Note (2) The “LED life time” is defined as the module brightness decrease to 50% original brightness at $T_a=25^\circ\text{C}$ and $I_L=360\text{ mA}$. The LED lifetime could be decreased if operating I_L is larger than 360 mA. The constant current driving method is suggested.

Note (3) LED Light Bar Circuit 9 S4P = 3 6 pcs LED

LED Source(CIRCUIT DIAGRAM)

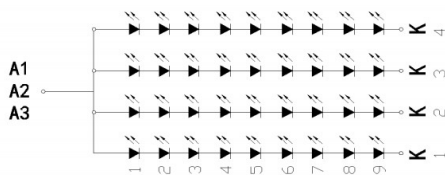

LCD 电路图

村田: NCU15XH103F6SRC

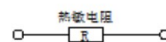

NTC 电路图

Pin assignment for Back light :

NO.	Symbol	Description
1	A1	Power LED anode power supply (+)
2	A2	Power LED anode power supply (+)
3	A3	Power LED anode power supply (+)
4	NC	No connection
5	K1	Power LED cathode power supply (-)
6	K2	Power LED cathode power supply (-)
7	K3	Power LED cathode power supply (-)
8	K4	Power LED cathode power supply (-)
9	NTC1	Thermistor(+)
10	NTC2	Thermistor(-)

NTC information :

Item	Value	Remark
Part number	NCU15XH103F6SRC	Murata
Resistance / Tolerance	10kΩ+/- 1%	Ta = 25°C
Permissive Operating Current (Max.)	0.31 mA	

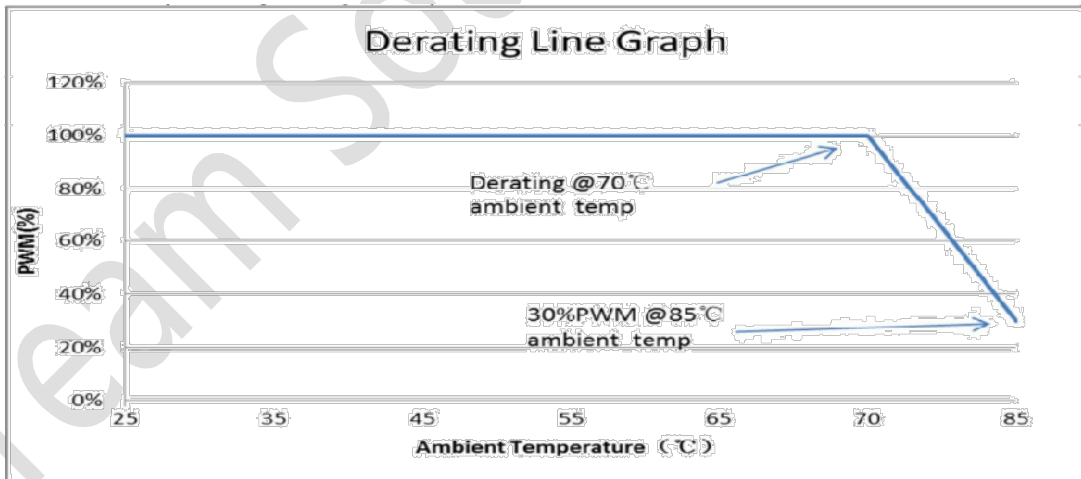

5 Absolute Maximum Ratings

Parameter	Symbol	Min.	Max.	Unit	Remarks
Power Supply Voltage	V _{DD}	-0.3	4	V	1 2 3 4
Logic Supply Voltage	V _{IN}	-0.3	V _{DD} +0.3	V	
Operating Temperature	T _{OP}	-30	85	°C	
Storage Temperature	T _{ST}	-40	90	°C	

6 Electrical Characteristics

Parameter	Symbol	Min.	Typ.	Max.	Unit	Remarks
Power Supply Voltage	VDD	-	3.3	-	V	2
Permissible Input Ripple Voltage	VRF	-	-	200	mV	-
Power Supply Current	IDD	-	-	TBD	mA	1
Power Supply Inrush Current	Inrush	-	-	1.5	A	2
Power Consumption	Mosaic	-	-	TBD	W	1

7 LCD Optical specifications

Item	Symbol	Condition	Specification			Unit	Remark
			Min	Typ	Max		
Response time (By Quick)	Tr+Tf	-	-	30	40	ms	Note 2
Contrast ratio	CR	-	-	1200	-	-	Note 3
Surface luminance	Lv	$\theta=0^\circ$	800	-	-	cd/m ²	Note 4
Luminance uniformity	Yu	$\theta=0^\circ$	80	-	-	%	Note 6
NTSC	-	$\theta=0^\circ$	70	75	-	%	Note 6
Viewing angle	Top	CR \geq 10	80	85	-	Deg.	Note 7
	Bottom	CR \geq 10	80	85	-		
	Left	CR \geq 10	80	85	-		
	Right	CR \geq 10	80	85	-		
CIE(x,y) chromaticity	Wx	$\theta=0^\circ$	Typ -0.04	0.300	Typ +0.04		Note 5
	Wy			0.320			
	Rx			0.657			
	Ry			0.320			
	Gx			0.283			
	Gy			0.606			
	Bx			0.138			
By	0.104						

Note 1: Ambient temperature = 25°C.

Note 2: Definition of response time:

The output signals of TRD-100 are measured when the input signals are changed to “White” (falling time) and from “White” to “Black” (rising time), respectively. The interval is between the 10% and 90% of amplitudes. Refer to figure as below.

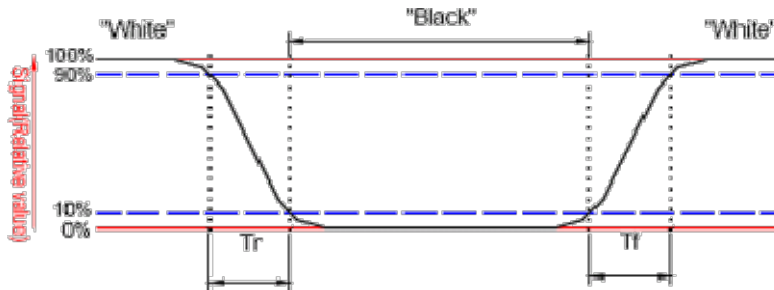

Note 3: Definition of contrast ratio:

Contrast ratio is calculated by the following formula.

$$\text{Contrast ratio (CR)} = \frac{\text{Brightness on the "white" state}}{\text{Brightness on the "black" state}}$$

Measured at the center area of the LCD.

Note 4: Definition of surface luminance

Surface luminance is the luminance with all pixels displaying white

Note 5: For contrast ratio, Surface Luminance, Luminance uniformity and CIE, the testing data is based on TOPCON's BM-7 photo detector or compatible.

Size : $S \leq 4.3''$ (see Figure A B)

H, V : Active area

Light spot size = 7.7mm (BM-7) 50cm distance or compatible distance from the LCD surface to detector lens.

test spot position : see Figure B.

measurement instrument : TOPCON's luminance meter BM-7 or compatible.

Size : $4.3 < S \leq 12.3''$ (see Figure A C)

H, V : Active area

Light spot size = 7.7mm (BM-7) 50cm distance or compatible distance from the LCD surface to detector lens.

test spot position : see Figure C.

measurement instrument : TOPCON's luminance meter BM-7 or compatible.

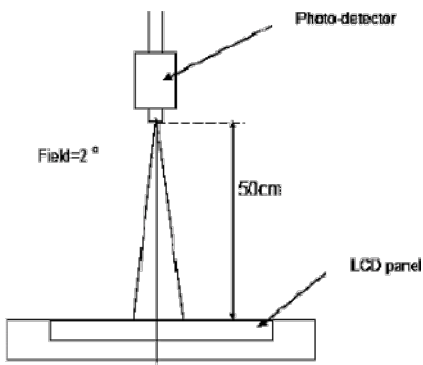

Figure A

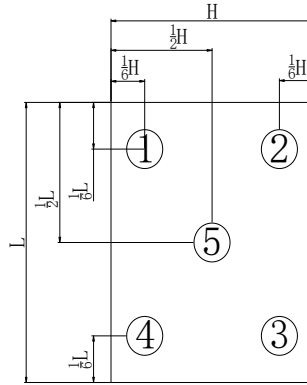

Figure B

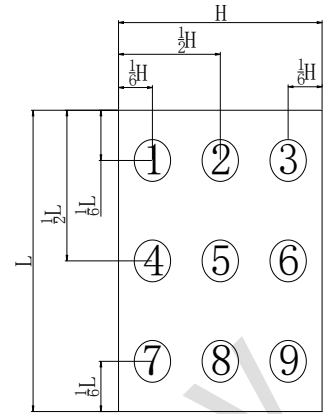

Figure C

Note 6: Definition of Luminance Uniformity

Active area is divided into 5 or 9 measuring areas, Every measuring point is placed at the center of each measuring area

Bmax: The measured maximum luminance of all measurement position.

Bmin: The measured minimum luminance of all measurement position.

Luminance Uniformity (Yu) = (Bmin/Bmax) x 100%

Note 7: Definition of viewing angle

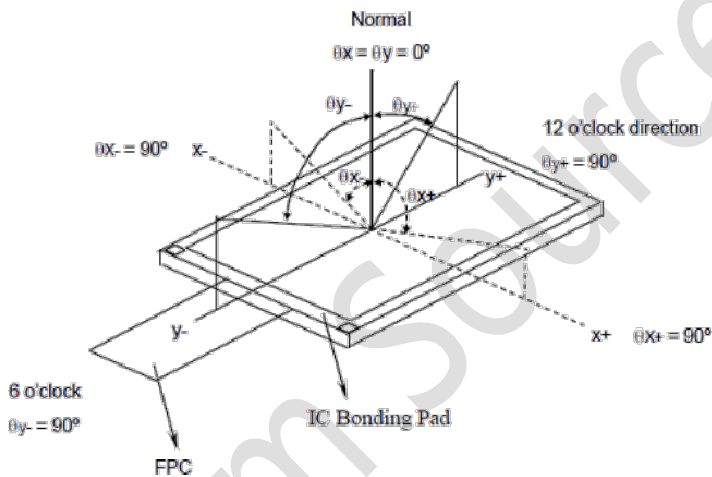

8 Touch Panel specifications

8.1 Mechanical characteristics

DESCRIPTION	INL SPECIFICATION	REMARK
Touch Panel Size	12.3	
Outline Dimension (OD)	332(H) x149.5(V) mm	Cover Lens Outline
Product Thickness	3.9mm(±0.3)	
Glass Thickness	3.0mm	
Ink View Area	293.03x110.51mm	
Input Method	5 Fingers	
Activation Force	Touch	
Surface Hardness	≥6H	

8.2 Electrical characteristics

DESCRIPTION	SPECIFICATION
Operating Voltage	DC 2.8~33V
Power Consumption (IDD)	Active Mode
	Sleep Mode
Interface	I ² C
Controller IC	ILI2511
I ² C address	-
Resolution	1920*720

8.3 Interface timing characteristics

PARAMETER	MIN	MAX	UNIT
SCL Frequency	-	400K	Hz
Bus Free Time Between a STOP and START Condition	1.3	-	uS
Hold Time (repeated) START Condition	0.6	-	uS
Data Setup Time	100	-	nS
Setup Time for Repeated START Condition	0.6	-	uS
Setup Time for STOP Condition	0.6	-	uS

9 RELIABILITY TEST

NO.	TEST ITEM	TEST CONDITION	INSPECTION AFTER TEST
1	High Temperature Storage	90±2°C/96 hours	Inspection after 2~4 hours storage at room temperature and humidity. The condensation is not accepted. The sample shall be free from defects: 1. Air bubble in the LCD 2. Seal leak 3. Non-display 4. Missing segments 5. Glass crack
2	Low Temperature Storage	-40±2°C/96 hours	
3	High Temperature Operating	85±2°C/96 hours	
4	Low Temperature Operating	-30±2°C/96 hours	
5	Temperature Cycle	-40±2°C ~ 25~ 85± 2°C × 100 cycles (30 min.) (5min.) (30min.)	
6	Damp Proof Test	60°C ±5°C × 90%RH/96 hours	
7	Vibration Test	Frequency 10Hz~55Hz Stroke: 1.5mm Sweep: 10Hz~150 Hz~10Hz 2 hours For each direction of X, Y, Z	
8	Packing Drop Test	Height: 50 cm 1 corner, concrete floor	
9	Electrostatic Discharge Test	C=150pF, R=330 Ω Air: ±8KV 150pF/330Ω 30 times Contact: ±4KV,20 times	
10	Image Sticking	25°C, 60%RH (ref. to Remark(1))	

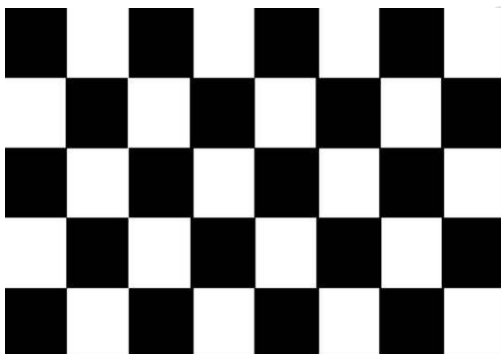

5*8 chess pattern

10 Image Sticking

10.1 What is image sticking?

If you remain a fixed image on LCD Display for a long period of time, you may experience a phenomenon called Image Sticking. Image Sticking - sometimes also called "image retention" or "ghosting" - is a phenomenon where a faint outline of a previously displayed image remains visible on the screen when the image is changed. It can occur at variable levels of intensity depending on the specific image makeup, as well as the amount of time the core image elements are allowed to remain unchanged on the screen. In POS applications, for example, a button menu which remains fixed, or in which the "frame" elements (core image) remain fixed and the buttons

may change, may be susceptible to image sticking. It is important to note that if the screen is used exclusively for this application, the user may never notice this phenomenon since the screen never displays other content. It is only when an image other than the “retained” image is shown on the screen that this issue becomes evident. Image sticking is different than the “burn-in” effect commonly associated with phosphor based devices.

10.2 What cause image sticking?

Image sticking is an intrinsic behavior of LCD displays due to the susceptibility to polarization of the interior materials (liquid crystals) when used under static, charged conditions (continuously displaying the same image). The individual liquid crystals in an LCD panel have unique electrical properties. Displaying a fixed pattern - such as the POS menu described above – over prolonged periods can cause a parasitic charge build-up (polarization) within the liquid crystals which affects the crystals’ optical properties and ultimately prevents the liquid crystal from returning to its normal, relaxed state when the pattern is finally changed. This effect takes place at a cellular level within the LCD, and the effect can cause charged crystal alignment at the bottom or top of a crystal cell in the “z” axis, or even crystal migration to the edges of a cell, again based on their polarity. These conditions can cause image sticking over an entire area, or at boundaries of distinct color change respectively. In either case, when the liquid crystals in the pixels and sub-pixels utilized to display the static image are polarized such that they can not return fully to their “relaxed” state upon deactivation, the result is a faint, visible, retained image on the panel upon presentation of a new, different image. The actual rate of image retention depends on variation factors such as the specific image, how long it is displayed unchanged, the temperature within the panel and even the specific panel brand due to manufacturing differences amongst panel manufacturers.

10.3 How to avoid image sticking?

- Try not to operate the LCD with a “fixed” image on the screen for more than 2 hours.
- If you are operating the monitor in an elevated temperature environment and with a displayed image which is contrary to the recommendations in “For Software Developers” below, image stick can occur in as little as 30 minutes. Adjust your screen saver settings accordingly.
- Power down the unit during prolonged periods of inactivity such as the hours a store is closed or a shift during which the piece of equipment isn’t used.
- Use a screensaver with a black or medium gray background that is automatically set to come on if the device is inactive for more than 5-10 minutes.
- Avoid placing the monitor in poorly ventilated areas or in areas that will create excess heat around the monitor for software developers.
- In defining the icons, buttons, or windows in the screen, try to utilize block patterns instead of distinct lines as borders for dividing the display into distinct areas.
- If it is necessary to display a static image, try to use colors that are symmetric to the middle grey level at the boundary of two different colors, and slightly shift the borders line once in a while.
- Try to utilize medium gray hues for those areas that will have prolonged display times or remain static as other menu elements change.

10.4 How to fix the image sticking?

Unlike the usually irreversible “burn-in” effects commonly associated with direct view phosphor display devices such as CRTs, an image retained on an LCD display can be reversed – often to a point of total invisibility. However, the severity of the underlying causes (as described above) of the image retained on a specific display, as well as the variation factors under which the retained image was created, will dictate the final level of retention reversal.

One way to erase a retained image on a panel is to run the screen (monitor "on") in an "all black" pattern for 4-6 hours. It is also helpful to do this in an elevated temperature environment of approximately 35° to 50°C. Again, utilizing a dynamic screen saver with an all black background during prolonged idle display periods is a good way to avoid image retention issues.

10.5 Is image sticking covered by TSD warranty?

Image sticking is a phenomenon inherent to LCD Display technology itself, and as such, the occurrence of this "ghosting" effect is considered normal operation by the manufacturers of the LCD display modules which are integrated into today' s monitor solutions. TSD does not warrant any display against the occurrence of image sticking. We strongly advise that you follow the operating recommendations listed above to avoid the occurrence of this phenomenon.

10.6 Others

1. Issues that are not defined in this document shall be discussed and agreed with both parties. (Customer and supplier)
2. Unless otherwise agreed upon in writing, the criteria shall be applied to both parties. (Customer and supplier)

11 Suggestions for using LCD modules

11.1 Handling of LCM

1. The LCD screen is made of glass. Don't give excessive external shock, or drop from a high place.
2. If the LCD screen is damaged and the liquid crystal leaks out, do not lick and swallow. When the liquid is attach to your hand, skin, cloth etc, wash it off by using soap and water thoroughly and immediately.
3. Don't apply excessive force on the surface of the LCM.
4. If the surface is contaminated, clean it with soft cloth. If the LCM is severely contaminated, use Isopropyl alcohol/Ethyl alcohol to clean. Other solvents may damage the polarizer. The following solvents is especially prohibited: water , ketone Aromatic solvents etc.
5. Exercise care to minimize corrosion of the electrode. Corrosion of the electrodes is accelerated by water droplets, moisture condensation or a current flow in a high-humidity environment.
6. Install the LCD Module by using the mounting holes. When mounting the LCD module make sure it is free of twisting, warping and distortion. In particular, do not forcibly pull or bend the I/O cable or the backlight cable.
7. Don't disassemble the LCM.
8. To prevent destruction of the elements by static electricity, be careful to maintain an optimum work environment.
 - Be sure to ground the body when handling the LCD modules.
 - Tools required for assembling, such as soldering irons, must be properly grounded.
 - To reduce the amount of static electricity generated, do not conduct assembling and other work under dry conditions.
 - The LCD module is coated with a film to protect the display surface. Exercise care when peeling off this protective film since static electricity may be generated.
9. Do not alter, modify or change the the shape of the tab on the metal frame.
10. Do not make extra holes on the printed circuit board, modify its shape or change the positions of components to be attached.
11. Do not damage or modify the pattern writing on the printed circuit board.

12. Absolutely do not modify the zebra rubber strip (conductive rubber) or heat seal connector
13. Except for soldering the interface, do not make any alterations or modifications with a soldering iron.
14. Do not drop, bend or twist LCM.

11.2 Storage

1. Store in an ambient temperature of 5 to 45 °C, and in a relative humidity of 40% to 60%. Don't expose to sunlight or fluorescent light.
2. Storage in a clean environment, free from dust, active gas, and solvent.
3. Store in antistatic container.

12 Limited Warranty

12.1

Our warranty liability is limited to repair and/or replacement. We will not be responsible for any consequential loss.

12.2

If possible, we suggest customer to use up all LCD modules as soon as possible. If the LCD module storage time over twelve months, we suggest to recheck it before being used.

12.3

Any product issues must be feedback to TSD within twelve months since delivery, otherwise, we will not be responsible for the subsequent or consequential events.