

1029CNH 10.1" IP65 Sunlight Readable Capacitive Touchscreen LED LCD Monitor w/ HDMI, DVI, VGA & AV Inputs



Description

Expanding its product line into previously uncharted territories, Xenarc Technologies Corp. presents the first in its class 10.1" direct sunlight readable, IP65 dust/splash proof, capacitive touchscreen display. The 1,000 NIT rated brightness of this water and dust resistant display makes it ideal for tough outdoor applications under direct sunlight, and also protects from environmental hazards with its IP65 certified casing.

The 1029CNH offers all of the innovation and inputs as our 1020 series models along with a Capacitive touchscreen panel. Capacitive sensing provides a more responsive touch interface than resistive touch. It achieves this by using the capacitance of human skin to detect the proximity or position of the input. Proximity sensing allows the touch interaction to work even if protective glass or coating is used over the display. The IP65 rating on the display provides for protection against solid objects and liquids. This display is guaranteed to prevent any amount of dust from entering the device, making it completely dust proof. Further, it is guaranteed to protect from water projected from a nozzle from having any harmful effect.

Why do our products outlast others in extreme conditions? Why do our products have a wider temperature range and a wider voltage input range? It is because our mission is to offer our customers the best products for any situation. By utilizing high grade components, this display is perfect for industrial, in-car computing applications or any other applications where a small, durable, environmentally rugged display is required.

Features

- For Marine, In-Car Computing, PC, Server, GPS, POS, and various HDMI/DVI/VGA Use
- IP65 / NEMA4 rated water and dust resistance
- 1,000NIT Sunlight Readable with long life LED backlight
- Projected Capacitive Multi-Touch Touchscreen (USB)
- Multi-Monitor Touchscreen Support
- HDMI Input x 1, VGA Input (15 pin D-SUB) x 1 & Video Input x 2
- DVI Input through included DVI to HDMI adaptor
- Supports HDCP
 - NTSC / PAL Multi-System
- 16x9 Aspect Ratio
- Ultra High Resolution - 1024 x 600 Native
- Solid Capacitors for improved durability
- Automatic backlight level adjustment through built-in ambient light sensor
- High Performance Image and Video Signal Processo
- **AISS** - Advanced Image-Scaling and Shaping
- Last Input memory
- Last Power setting memory
- IR Remote Control
- Auto power-on upon signal detection
- Automatic display adjustment
- On Screen Display Control
- Mirror Image Flip
- Vertical Image Flip
- Function to disable front button(s)
- Function to disable On Screen Text
- AV2 Auto Switching for backup camera
- U-Shape mounting bracket
- VESA 75mm mounting holes
- 26-Pin heavy-duty connector with connector locking
- Anti Reflective Coating
- Brushed aluminum face plate
- Aluminum Casing
- Supports 10V DC ~ 35V DC
- "E" Mark Certified for Automotive use

Function Diagram

How does it work?

- Connect the included cable to the Monitor
- Connect the connectors to your devices
- Install Touch Screen Driver



[CNH Series]

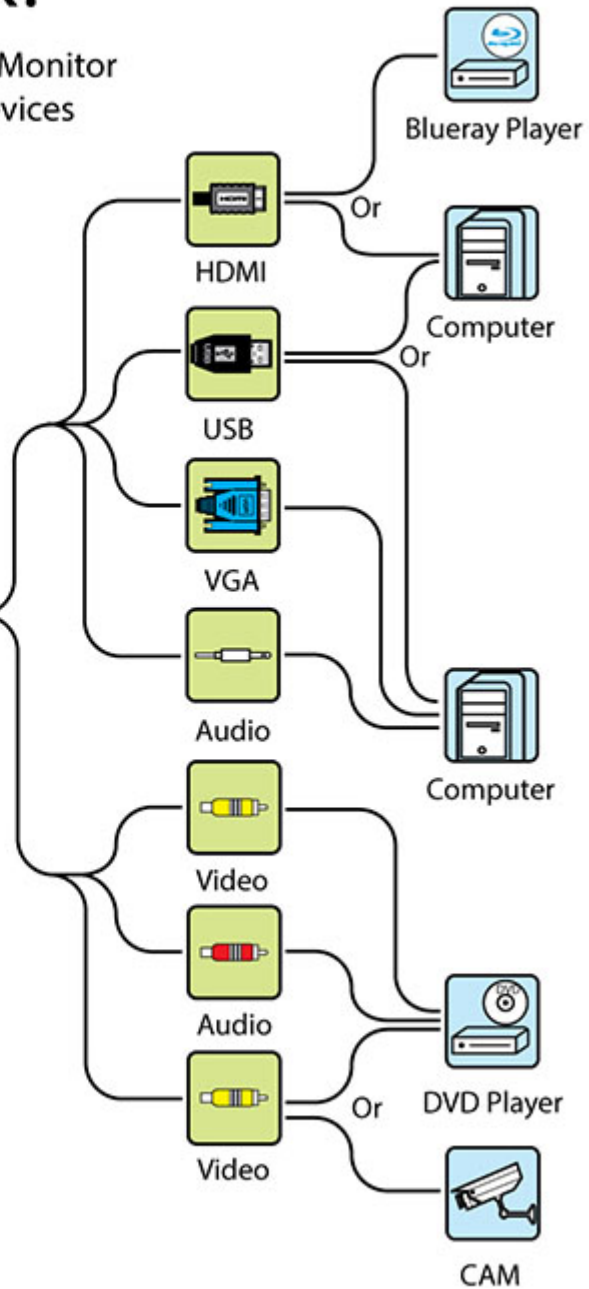
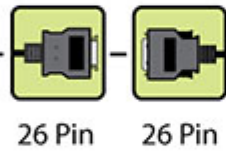

XENARC
TECHNOLOGIES

Package Contents

- U-Shape mount
- AC adaptor
- 1.8M Connection cable (5M version available separately)
- Cigarette lighter car adaptor

Specification

- Screen Size: Diagonal 10.1" (16:9)
- Physical Resolution: 1024 (H) x 600 (V) WXGA
- Supported Resolution: 640 x 480 ~ 1920 x 1080
- Dot Resolution: 3072 x 600 = 1,812,000 (dots)
- Brightness: 1000 cd/m²
- Contrast Ratio: 500:1
- Viewing Angle: 140° Horizontal, 110° Vertical
- Response Time (Tr/Tf): 5/20ms (Typ.)
- Touch Screen Interface: USB port
- Operating Voltage Range: DC 10V ~ 35V
- Power Supply: DC 12V
- Power Consumption: ? 20W
- Operating Temperature: -4°F ~ 158°F (-20°C ~ 70°C)
- Storage Temperature: -22°F ~ 176°F (-30°C ~ 80°C)
- Dimension (mm): 265.7W x 178.2H x 32.2D
- Weight (lb): 3.64
- FCC, CE, E13 Certification
- IP65 / NEMA4 Rated
- ROHS Compliant
- 24 Month Warranty
- 30 days No dead Pixel Guarantee