

# AFP-6152

15" Stainless Fanless Touch Panel Computer With Intel® Atom™ D525 Processor, 2GB RAM

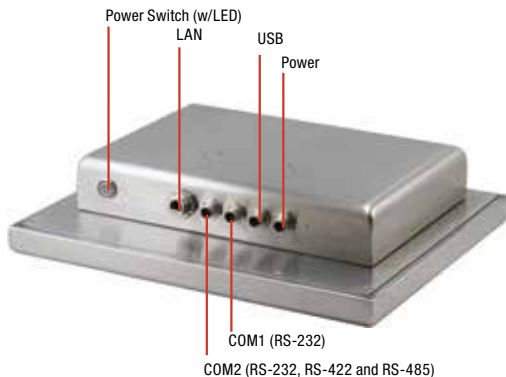
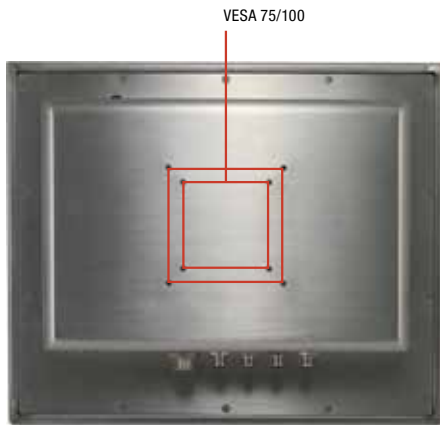

## Features

- 15" XGA (1024 x 768) TFT LCD Display
- Intel® Atom™ D525 Processor, Fanless Operation
- IP66/NEMA4x-Compliant Stainless Type 316L System
- Wide Operation Temperature : -20°C ~ 50°C
- Anti-Scratch Touch Screen: 7H
- Power Input Protection:
  - Over-Voltage Protection
  - Low-Voltage Protection
  - Reverse Protection

Note: Factory-installed Storage Device is recommended for IP66 Protection.



## Specifications

System	
Processor	Intel® Dual Core Atom™ D525 CPU, 1.8GHz onboard
Memory	DDR3 SODIMM x 1 up to 4GB (Wide-Temp. and Factory- Installed)
LCD/CRT Controller	Integrated in Processor
Ethernet	10/100/1000Base-TX x 1
I/O Port	M12 x 1 for USB 2.0 x 2 M12 x 1 for RS-232 x 1 M12 x 1 for RS-232/422/485 x 1 M12 x 1 for LAN x 1 Power input x 1
Storage Disk Drive	2.5" SATA Hard Disk Drive x 1/ CompactFlash™ Slot x 1 (Internal) (Wide-Temp. and Factory- Installed)
Expansion Slot	Mini-card x 1
OS Support	Window® XP, Window® 7, Linux Fedora
Mechanical	
Construction	IP66 / NEMA4x for stainless front bezel & stainless chassis
Mounting	VESA 75/100
Dimension	15.75" (W) x 12.76" (H) x 3.32" (D) (390 mm x 324mm x 84.5mm)
Carton Dimension	20.47" x 18.5" x 9.06" (520mm x 470mm x 230mm)
Gross Weight	16.1 lb (7.5Kg)
Net Weight	13.2 lb (6 Kg)
Environmental	
Operating Temperature	-4°F ~ 122°F (-20°C ~ 50°C) Ambient without Airflow -4°F ~ 130°F (-20°C ~ 55°C) Ambient with Airflow
Storage Temperature	-4°F ~ 158°F (-20°C ~ 70°C)
Storage Humidity	8%~90% @40°C, non-condensing
Vibration	1g rms/ 5~500Hz/ Random operation (HDD)
Shock	20 G peak acceleration (11 msec. Duration)
EMC	CE/FCC Class A
Power Supply	
DC input	9~30V DC input -Over-voltage protection -Low-voltage protection -Reverse protection
LCD	
Display type	15" TFT-LCD
Max Resolution	1024 x 768
Max. Colors	262K colors
Luminance	400
Viewing Angle	160°(H)/140°(V)
Back Light	LED
Back Light MTBF (hours)	50,000
Touchscreen	
Type	Glass-Film-Glass touch, anti-scratch 7H
Light Transmission	80%
Lifetime (Times)	10 millions times

# AFP-6152

## Dimension

Unit: mm

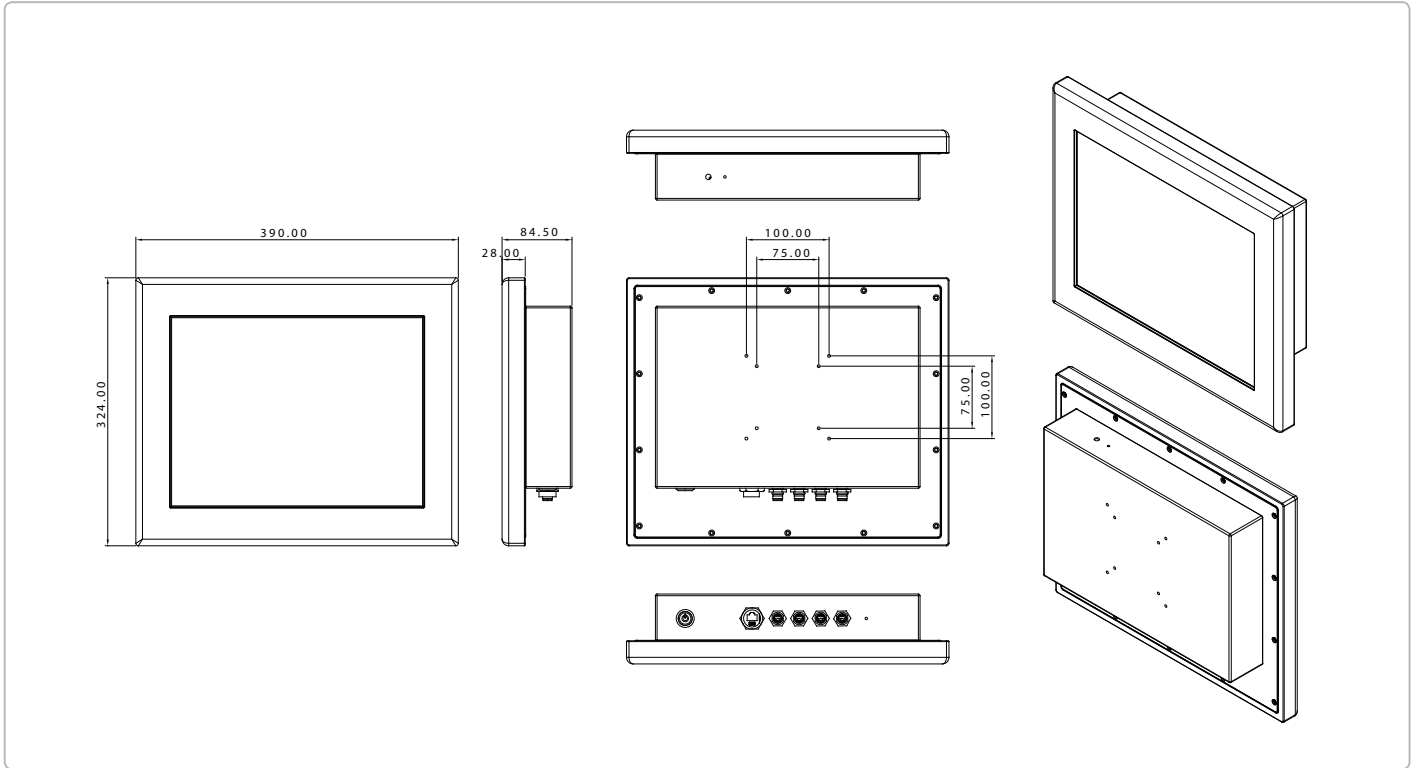

## Ordering Information

Part Number	Display Type	Max Resolution	Luminance	View Angle	Backlight MTBF (Hours)	CPU	LAN	USB	RS-232	RS-485/422/232	Storage	RAM	Display	Expansion	Mounting	Power	Temp.	Touch
TF-AFP-6152HTT-A1-1010	15" TFT-LCD	1024 x 768	400 cd/m <sup>2</sup>	160(H), 140(V)	50,000	Intel® Atom™ D525 - 1.8 GHz	1	2	1	1	CF Kit x 1 SATA-HDD Kit x 1	2GB	VGA x 1	Mini Card x 1	VESA75/100	DC 9-30V	-20°C-50°C (w/o air)	GFG Touch

## Packing List

- USB Cable with 2 USB Waterproof Connectors
- COM Cables with Waterproof Connectors
- Waterproof Connector for DC-in (Female)
- Product CD
- AFP-6152

## Optional Accessories

- **1757910004**  
AC Adapter (100W)
- **1757910802**  
AC Adapter Power Cord (US Type)
- **1757910803**  
AC Adapter Power Cord (European Type)
- **175791080E**  
AC Adapter Power Cord (Japanese Type)
- **9761215304**  
Water-proof Wireless Module (b/g/n)