

12.1" XGA Rugged Touch Display



Features

- 12.1" XGA (1024 x 768) TFT LCD Display
- IP65 Aluminum Die Cast Front Bezel
- 5-Wire Resistive Touch/ Non-Touch Screen Supported
- Power Protection: (DC 12V/ DC 9-30V)
 - Over-Voltage Protection
 - Under-Voltage Protection
 - Reverse-Voltage Protection
- Flexible Interfaces:
 - DVI/VGA For Video Input
 - RS-232 For Touch Screen



Specifications

System	
Input Signal	VGA/DVI
On Screen Display Control	LCD On/Off, Auto, Menu, Up, Down
I/O Connector	VGA/DVI, RS-232 (For T/S)
OS Support	Windows® XP, Windows® 7, Windows® 8.1, Windows® 10, Linux Fedora
Mechanical	
Construction	IP65/ NEMA4 aluminum die cast front bezel & steel chassis
Mounting	Panel mount/ Rackmount/ VESA 75/100/ Wallmount/ Desktop
Dimension	13.61" x 10.46" x 2.41" (345.8mm x 265.8mm x 61.1mm)
Carton Dimension	20.67" x 18.31" x 9.1" (525mm x 465mm x 230mm)
Gross Weight	13 lb (5.9 kg)
Net Weight	9 lb (4.1 kg)
Environmental	
Operating Temperature	-4°F ~ 140°F (-20°C~60°C)
Storage Temperature	-4°F ~ 140°F (-20°C~60°C)
Storage Humidity	10~95% @ 40°C, non-condensing
Vibration	1 Grms/ 5~500Hz/ random operation
Shock	10G peak acceleration (11 msec. duration)
EMC	CE/FCC class A
Power Supply	
DC Input	DC 12 V/ 9~30V, w/3-pin terminal block Over-voltage (31V _{DC}) Under-voltage (8V _{DC}) Reverse-voltage protection Surge protection (1000V _{DC})
LCD	
Display Type	12.1" TFT-LCD
Max. Resolution	1024 x 768
Max. Colors	16.7M colors (6/8-bit for R,G,B)
Luminance	500 cd/m ²
Viewing Angle	160°(H), 160°(V)
Back Light	LED
Back Light MTBF (Hours)	50,000
Touchscreen	
Type	5-wire resistive (AGD-312DHTT-V2A-1010/ AGD-312DHTT-V2B-1010)
Light Transmission	80% (±5%)
Lifetime (Times)	10 million activations

AGD-312D V2

Dimension

Unit: mm

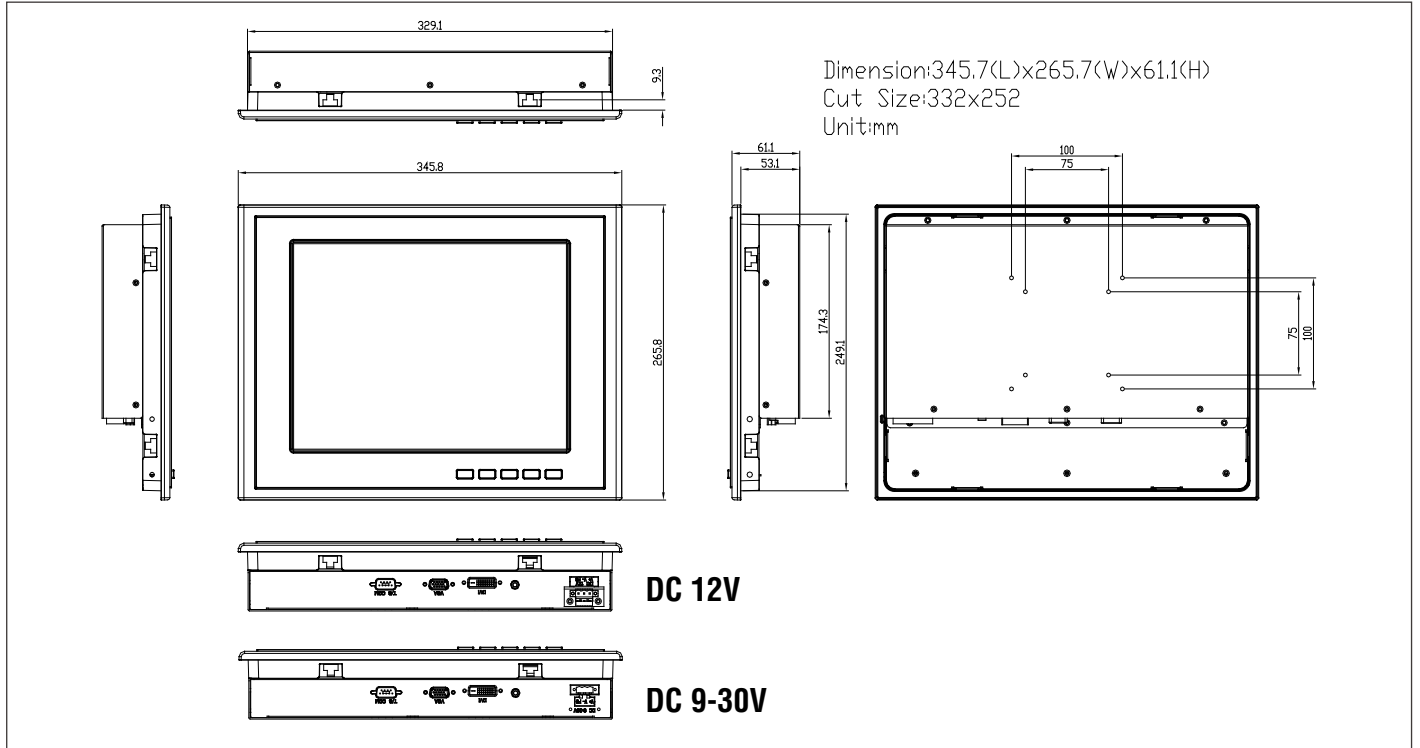

Ordering Information

Part Number	Display Type	Max. Resolution	Luminance	View Angle	Backlight MTBF (Hours)	Display	Mounting	Power	Temp.	Touch	Other
AGD-312DHTT-V2A-1010	12.1" TFT-LCD	1024 x 768	500 cd/m ²	160(H), 160(V)	50,000	VGA x 1 DVI x 1	Panel mount/ VESA 75/100/ Wallmount	DC 12V	-20°C ~ 60°C (w/ air)	5-wire resistive	—
AGD-312DHTT-V2B-1010	12.1" TFT-LCD	1024 x 768	500 cd/m ²	160(H), 160(V)	50,000	VGA x 1 DVI x 1	Panel mount/ VESA 75/100/ Wallmount	DC 9~30V	-20°C ~ 60°C (w/ air)	5-wire resistive	—
AGD-312D -V2A-1010	12.1" TFT-LCD	1024 x 768	500 cd/m ²	160(H), 160(V)	50,000	VGA x 1 DVI x 1	Panel mount/ VESA 75/100/ Wallmount	DC 12V	-20°C ~ 60°C (w/o air)	—	—
AGD-312D-V2B-1010	12.1" TFT-LCD	1024 x 768	500 cd/m ²	160(H), 160(V)	50,000	VGA x 1 DVI x 1	Panel mount/ VESA 75/100/ Wallmount	DC 9~30V	-20°C ~ 60°C (w/o air)	—	—

Packing List

- VGA Cable
- RS-232 Cable
- Product CD
- AGD-312D V2

Optional Accessories

- **1700151806**
VGA Cable, 180cm
- **1700091800**
DB-9, 180cm, RS-232 For Touch Screen
- **1255900841**
AC/DC 12V Power Adapter, 84W
- **1702031802**
Power Cord (US Type)
- **1702031803**
Power Cord (European Type)
- **170203180E**
Power Cord (Japanese Type)