

AV710

MIL-STD FANLESS RUGGED SYSTEM WITH INTEL® CORE™ I7-6822EQ PROCESSOR, IP65 PROTECTION, MIL-STD D38999 CONNECTORS, 9V TO 36V DC-IN, WIDE TEMP. -40 TO 70°C

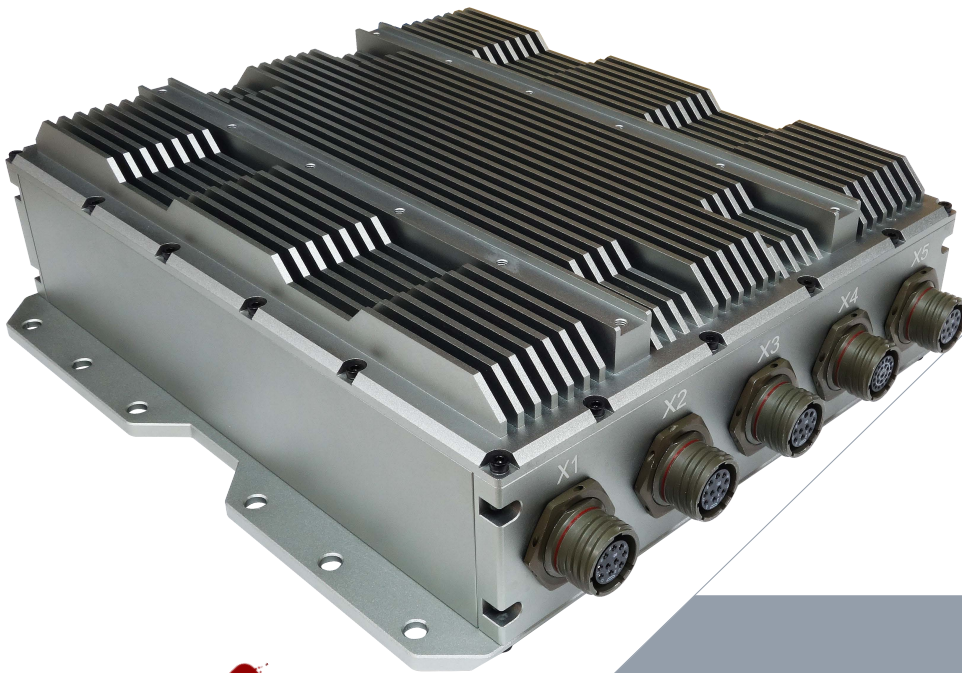

WWW.STACKRACK.COM

COMPLIANT

MIL-STD
461/1275/704
D0160



- DESIGN FOR RELIABILITY UNDER DEMANDING MIL-STD-810G THERMAL, SHOCK, VIBRATION, HUMIDITY/EMI/EMC CONDITIONS
- INTEL® CORE™ I7-6822EQ PROCESSOR (2.8GHZ, 4 CORES, 8 THREADS)
- UP TO 32GB DDR4 MEMORY
- 1 X VGA, 2 X GIGABIT ETHERNET, 2 X USB, 2 X COM
- RUGGED MIL-DTL-38999 CONNECTORS
- 9V~36V DC-IN
OPTIONAL MILITARY-GRADE DC/DC 12-40V DC-IN
- EXTENDED TEMPERATURE -40 TO 70°C

FEATURES

- **Ultra-High Performance Intel® Core i7® Processor**

Core i7-6822EQ

is a 64-bit quad-core x86 high-end performance mobile microprocessor, which is based on the Skylake microarchitecture and is fabricated on a 14 nm process, has a base frequency of 2.0 GHz and a turbo boost frequency of up to 2.8 GHz with a TDP of 25 W. This processor incorporates the HD Graphics 530 integrated graphics operating at 350 MHz with a turbo frequency of 1 GHz. This model supports 64 GiB of dual-channel DDR4-2133 memory.



6th Generation processor has the following security, data protection and/or software features: Intel Secure Key, vPro technology, Identity Protection technology, OS Guard and Boot Guard. The CPU is compatible with DirectX 12, OpenGL 4.4, OpenCL 2.0 and Vulkan1.0.31 APIs. The graphics unit has the following software features enabled: Intel Wireless Display, Quick Sync Video, Clear Video technology, Clear Video HD technology, InTru 3D technology and Insider.

Integrated Graphics

GPU Type: HD 530

Graphics tier: GT2

Microarchitecture: Gen 9

Execution units: 24

Base frequency (MHz): 350

Maximum frequency (MHz): 1000

- **MIL-STD-1275/704 Power supply with Voltage transient protections**

To enhance reliability, HORUS200 is designed for rugged extremes. durable metal casing with an isolated MIL-STD-1275, MIL-STD 704 and DO-160 power supply in an IP50 (dustproof) ultra durable metal /aluminum chassis that protects against vehicle/aircraft voltage surges, spikes and transients is well suited for the strictest military requirement and deliver optimal performance in harsh conditions.

The GAIA Hi-Rel DC/DC CONVERTER it also provides Undervoltage Lockout (UVLO), Output Over Current Protection (OCP), Output Overvoltage Protection (OVP) and Over Temperature Protection (OTP) to made stability and safty.



Power Block Diagram

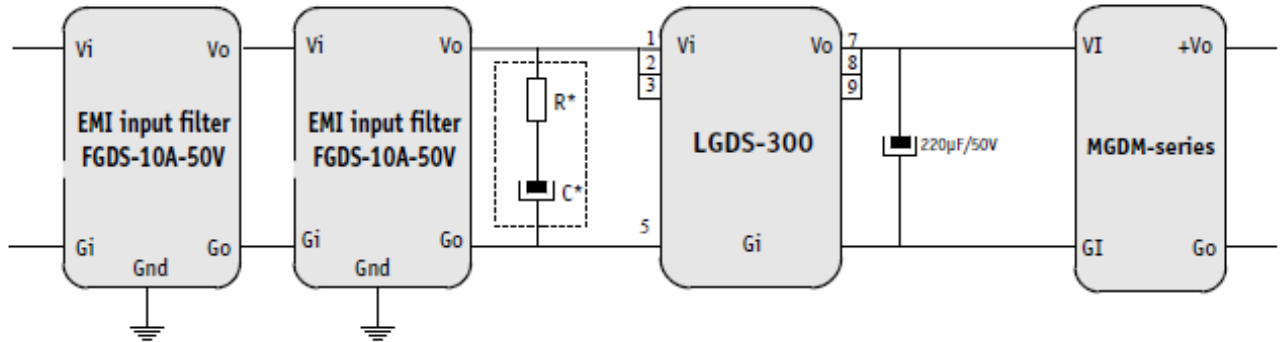

Module Compliance with MIL-STD-461C/D/E Standards

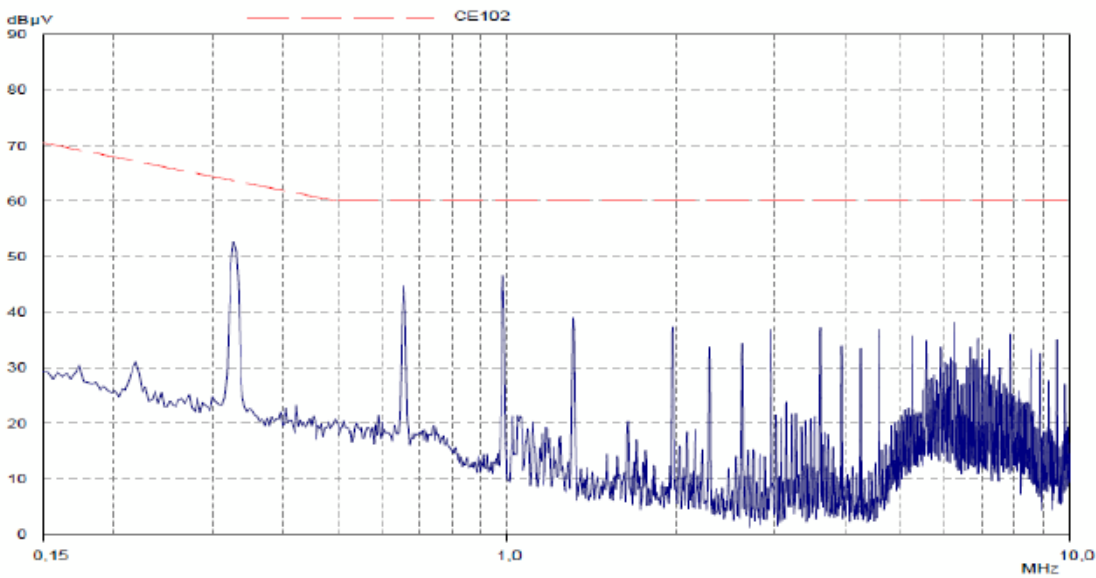

MIL-STD-461E : MGDS-15x-H-J with FGDS-10A-50V

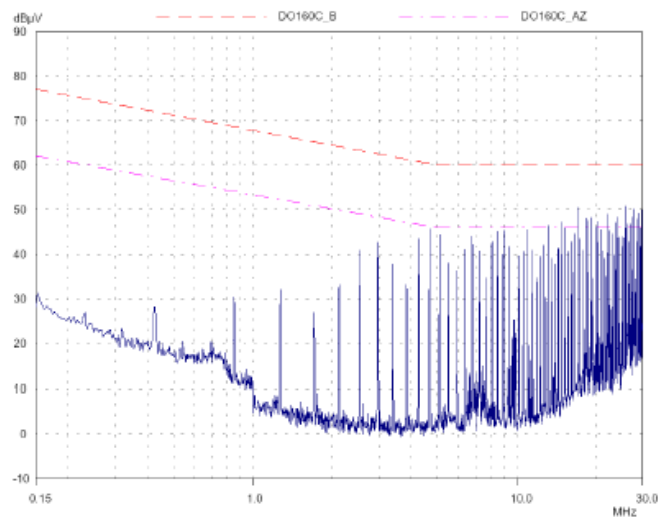

DO-160G : MGDS-15x-H-J with FGDS-10A-50V

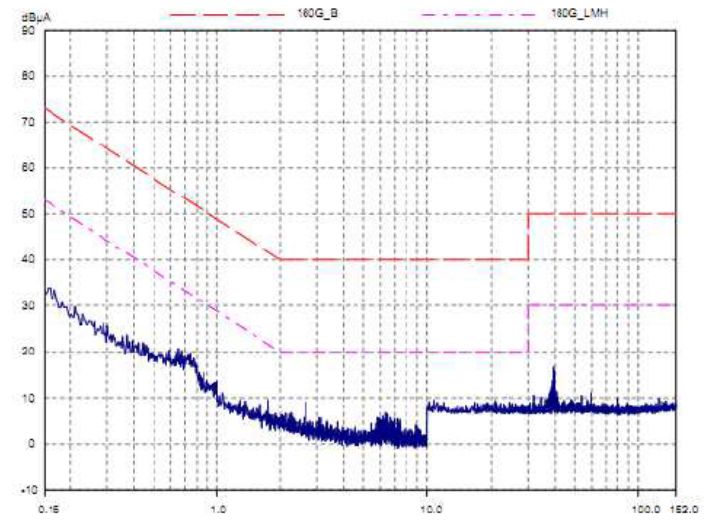

SPECIFICATIONS

SPECIFICATIONS	
High Performance Processor	Intel® Core™ i7-6822EQ Processor (Frequency 2.0GHz, Turbo Boost Frequency up to 2.8GHz), 4-Core, 8 Thread Support, 8MB SmartCache. Build-in Turbo Boost Technology 2.0, VPro and Hyper-Threading support.
Memory	2 x SODIMMs up to 32GB DDR4 2133MHz SDRAM
Chipset	Intel® QM170 Platform Controller Hub
DISPLAY	
Graphics Processor	Intel® HD Graphics 530
Resolution	Up to 1920x1080@60Hz 32bpp
STORAGE	
HDD/SSD	1 x 2.5" SSD
ETHERNET	
Ethernet	1x Intel® i210IT Gigabit Ethernet 1x Intel® i219LM Gigabit Ethernet
FRONT I/O	
DC-In	1 (Amphenol TV07RW-11-54P)
Power Button	1 x Power Button with LED backlight
Ground Screw	1 x M4 Screw
REAR I/O	
X1	1 x LAN (Amphenol TV07RW-13-98S)
X2	1 x LAN (Amphenol TV07RW-13-98S)
X3	2 x USB (Amphenol TV07RW-13-98S)
X4	2 x COM (Amphenol TV07RW-13-35S)
X5	1 x VGA (Amphenol TV07RW-13-98S)
POWER REQUIREMENT	
Power Input	Standard: DC-In 9~36V Optional : MIL-STD-1275, MIL-STD 704 and DO-160 power supply , 12 to 40V (150W max)

APPLICATIONS, OPERATING SYSTEM

Applications	Commercial and Military Platforms Requiring Compliance to MIL-STD-810G Embedded Computing, Process Control, Intelligent Automation and manufacturing applications where Harsh Temperature, Shock, Vibration, Altitude, Dust and EMI Conditions. Used in all aspects of the military.
Operating System	Windows 10 64Bit Ubuntu14.04, Fedora 20/23, RedHat Linux EL 7.1/7.2

PHYSICAL

Dimension (W x D x H)	230 x 83 x 280mm (9.06" x 3.27" x 11.02")
Weight	6.0 Kg (13.2lbs)
Chassis	Aluminum Alloy, Corrosion Resistant
Finish	Anodic aluminum oxide (Color Iron gray)
Cooling	Natural Passive Convection/Conduction. No Moving Parts
Ingress Protection	IP65

ENVIRONMENTAL

MIL-STD-810G Test	<p>Method 507.5, Procedure II (Temperature & Humidity)</p> <p>Method 516.6 Shock-Procedure V Non-Operating (Mechanical Shock)</p> <p>Method 516.6 Shock-Procedure I Operating (Mechanical Shock)</p> <p>Method 514.6 Vibration Category 24/Non-Operating (Category 20 & 24, Vibration)</p> <p>Method 514.6 Vibration Category 20/Operating (Category 20 & 24, Vibration)</p> <p>Method 501.5, Procedure I (Storage/High Temperature)</p> <p>Method 501.5, Procedure II (Operation/High Temperature)</p> <p>Method 502.5, Procedure I (Storage/Low Temperature)</p> <p>Method 502.5, Procedure II (Operation/Low Temperature)</p> <p>Method 503.5, Procedure I (Temperature shock)</p>
Reliability	<p>No Moving Parts; Passive Cooling.</p> <p>Designed & Manufactured using ISO 9001/2000 Certified Quality Program.</p>
EMC compliance	<p>MIL-STD-461E :</p> <p>CE102 basic curve, 10kHz - 30 MHz</p> <p>RE102-4, (1.5 MHz) -30 MHz - 5 GHz</p> <p>RS103, 1.5 MHz - 5 GHz, 50 V/m equal for all frequencies</p> <p>EN 61000-4-2: Air discharge: 8 kV, Contact discharge: 6kV</p> <p>EN 61000-4-4: Signal and DC-Net: 1 kV</p> <p>EN 61000-4-5: Leads vs. ground potential 1kV, Signal und DC-Net: 0.5 kV</p> <p>EN 61000-4-2: Air discharge: 8 kV, Contact discharge: 6kV</p> <p>EN 61000-4-4: Signal and DC-Net: 1 kV</p> <p>EN 61000-4-5: Leads vs. ground potential 1kV, Signal und DC-Net: 0.5 kV</p> <p>EN 61000-4-2: Air discharge: 8 kV, Contact discharge: 6kV</p> <p>EN 61000-4-4: Signal and DC-Net: 1 kV</p> <p>EN 61000-4-5: Leads vs. ground potential 1kV, Signal und DC-Net: 0.5 kV</p> <p>EN 55022, class A</p> <p>EN 61000-4-3: 10V/m</p> <p>CE and FCC</p>
Operating Temperature	-40 to 70°C
Storage Temperature	-40 to 85°C

DIMENSIONS

