

UD info Corp.

Industrial CF Express PCIe SSD

CFX-21UF Series

Product DataSheet

UD info CORP.

3F-4, No.8, Ln. 609, Sec. 5, Chongxin Rd., Sanchong Dist., New Taipei City 241, Taiwan (R.O.C.)

TEL: +886-2-7713-6050 FAX: +886-2-8511-3151

E-mail: sales@UDinfo.com.tw

1.	Introduction	6
1.1.	General Description	6
1.2.	Block Diagram	6
2.	Product Specifications	7
3.	Environmental Specifications	9
3.1.	Environmental Conditions	9
3.1.1.	Temperature and Humidity	9
3.1.2.	Shock	10
3.1.3.	Vibration	10
3.1.4.	Drop	10
3.1.5.	Bending	10
3.1.6.	Torque	10
3.1.7.	Electrostatic Discharge (ESD)	11
3.1.8.	EMI Compliance	11
3.2.	MTBF	11
3.3.	Certification & Compliance	11
4.	Electrical Specifications	12
4.1.	Supply Voltage	12
4.2.	Power Consumption	12
5.	Interface	14
5.1.	Pin Assignment and Descriptions	14
6.	Supported Commands	16
6.1.	NVMe Command List	16
6.2.	Identify Device Data	17
6.3.	SMART Attributes	21
7.	Physical Dimension	22
8.	Terminology	23
9.	Barcode description	23
10.	Partnumber decoder	24



Revision History

Revision	Draft Date	History	Author
1.0	2018/8/15	New release	Golden Lee
1.1	2018/12/10	Removed OPAL	Golden Lee



Product Overview

- **Capacity**
 - 32GB up to 512GB
- **Form Factor**
 - CFX
- **PCIe Interface**
 - NVMe PCIe Gen3 x2
- **Compliance**
 - NVMe 1.3
 - PCI Express Base 3.1
- **Flash Interface**
 - Transfer rate up to 533MBps
 - Up to 4pcs of BGA flash
- **Performance**
 - Read up to 1,600 MB/s
 - Write up to 1,000 MB/s
- **Power Consumption**^{Note1}
 - Active mode: < 3.1W
 - Idle < 50 mW
 - L1.2 < 2 mW
- **Reliability**
 - MTBF more than 1,500,000 hours
 - Uncorrectable Bit Error Rate(UBER)
< 1 sector per 10¹⁶ bits read
- **Advanced Flash Management**
 - Static and Dynamic Wear Leveling
 - Bad Block Management
 - TRIM
 - SMART
 - Over-Provision
- **Power Saving Modes**
 - Support APST
 - Support ASPM
 - Support L1.2
- **Temperature Range**
 - Operation (Standard): 0°C ~ 70°C
 - Storage: -40°C ~ 85°C
- **Compliant**
 - RoHS
 - CE & FCC
- **Feature Support List:**
 - End to end data path protection
 - Thermal throttling
 - SmartECC
 - SmartRefresh
 - Drive log
 - Support HMB(Host Memory Buffer)
Note3

Notes:

1. Please see "Power Consumption" for details.
2. Supported by a separate firmware version. Further information available upon request.
3. Win 10(version 1703) and above supports HMB(Host Memory Buffer) function.

1. INTRODUCTION



1.1. General Description

UDinfo's CF Express PCIe solid state Drive delivers all the advantages of flash disk technology with PCIe Gen3 x2 interface. The CF Express could provide the capacity range from 32GB to 512GB. Moreover, it can reach up to 1600 MB/s read as well as 1000 MB/s write high performance. Its lower power consumption makes it an ideal storage choice for high performance embedded platforms.

1.2. Block Diagram

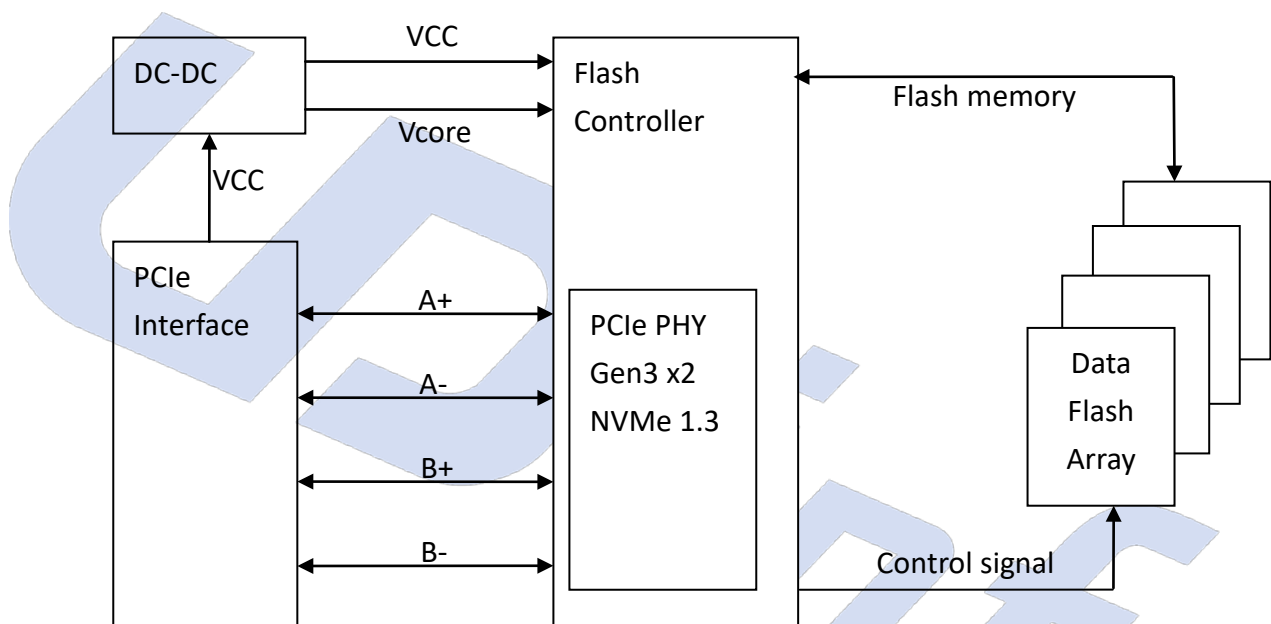

CF Express PCIe SSD Block Diagram

2. PRODUCT SPECIFICATIONS



- **Capacity**
 - 32GB up to 512GB
- **Electrical/Physical Interface**
 - PCIe Interface
 - Compliant with NVMe 1.3
 - PCIe Express Base Ver 3.1
 - PCIe Gen3 x 2 lane and backward Compatible to PCIe Gen2 and Gen1
 - Support up to QD 128 with queue depth of up to 64K
 - Support power management
- **Supported NAND Flash**
 - Toshiba 3D NAND; Intel/Micron 3D NAND; Hynix 3D NAND
 - Support all types of large block
 - Support up to 4pcs of BGA flash
- **ECC Scheme**
 - Applies the StrongECC™ (SECC) of ECC algorithm
- **Sector Size Support**
 - 512B
 - 4KB
- **UART / GPIO**
- **Support SMART and TRIM commands**
- **LBA Range**
 - IDEMA standard

- Performance

- 3D Bics3 with HMB (Host Memory Buffer)

Capacity	Flash Structure	CE#	Flash Type	Sequential (CDM)		Random (8GB Burst)	
				Read (MB/s)	Write (MB/s)	Read (KIOPS)	Write (KIOPS)
32GB	32GB x 1	1	BGA, BiCS3 TLC	370	110	20	20
64GB	32GB x 2	2	BGA, BiCS3 TLC	750	230	45	50
128GB	64GB x 2	4	BGA, BiCS3 TLC	1,450	450	90	100
256GB	64GB x 4	8	BGA, BiCS3 TLC	1,550	900	180	170
512GB	128GB x 4	16	BGA, BiCS3 TLC	1,600	1,000	230	180

- 3D Bics3 without HMB (Host Memory Buffer)

Capacity	Flash Structure	CE#	Flash Type	Sequential (CDM)		Random (8GB Burst)	
				Read (MB/s)	Write (MB/s)	Read (KIOPS)	Write (KIOPS)
32GB	32GB x 1	1	BGA, BiCS3 TLC	360	110	12	20
64GB	32GB x 2	2	BGA, BiCS3 TLC	720	230	22	45
128GB	64GB x 2	4	BGA, BiCS3 TLC	1,400	450	45	80
256GB	64GB x 4	8	BGA, BiCS3 TLC	1,550	850	90	120
512GB	128GB x 4	16	BGA, BiCS3 TLC	1,550	950	120	150

Notes:

1. The performance was estimated based on Toshiba NAND flash.
2. Performance may differ according to flash configuration and platform.
3. The tables are for reference only. The criteria for accepting goods shall be further discussed based on different flash configuration.
4. Performance is measured with following conditions
 - (a) CrystalDiskMark 5.1.2, 1GB range, QD=32, Thread=1
 - (b) IOMeter, 8GB range, 4K data size, QD=32
 - (c) OS Version: Win10 (64bit), version 1703

3. ENVIRONMENTAL SPECIFICATIONS



3.1. Environmental Conditions

3.1.1. Temperature and Humidity

- Temperature:
 - ◆ Storage: -40°C to 85°C
 - ◆ Operational (Standard grade): 0°C to 70°C
- Humidity:
 - ◆ Standard grade: RH 90% under 40°C (operational)

■ High Temperature Test Condition

	Temperature	Humidity
Operation (Standard)	70°C	0% RH
Storage (Standard)	85°C	0% RH

Result: No any abnormality is detected.

■ Low Temperature Test Condition

	Temperature	Humidity
Operation (Standard)	0°C	0% RH
Storage (Standard)	-40°C	0% RH

Result: No any abnormality is detected.

■ High Humidity Test Condition

	Temperature	Humidity
Operation (Standard)	40°C	90% RH
Storage (Standard)	40°C	93% RH

Result: No any abnormality is detected.

■ Temperature Cycle Test

	Temperature
Operation (Standard)	0°C
	70°C
Storage (Standard)	-40°C
	85°C

Result: No any abnormality is detected.

3.1.2. Shock

■ Shock Specification

	Acceleration Force
Non-Operational	1500G

Result: No any abnormality is detected.

3.1.3. Vibration

■ Vibration Specification

	Condition	
	Frequency/Displacement	Frequency/Acceleration
Non-Operational	20Hz~80Hz/1.52mm	80Hz~2000Hz/20G

Result: No any abnormality is detected.

3.1.4. Drop

■ Drop Specification

	Height of Drop	Number of Drop
Non-operational	80cm free fall	6 face of each unit

Result: No any abnormality is detected.

3.1.5. Bending

■ Bending Specification

	Force	Action
Non-operational	≥ 20N	Hold 1min/5times

Result: No any abnormality is detected.

3.1.6. Torque

■ Contact ESD Specification

	Force	Action
Non-operational	0.5N-m or ±2.5 deg	Hold 1min/5times

Result: No any abnormality is detected.

3.1.7. Electrostatic Discharge (ESD)

Specification	+/- 4KV
EN 55024, CISPR 24 EN 61000-4-2 and IEC 61000-4-2	Device functions are affected, but EUT will be back to its normal or operational state automatically.

3.1.8. EMI Compliance

Specification
EN 55032, CISPR 32 (CE) AS/NZS CISPR 32 (CE) ANSI C63.4 (FCC) VCCI-CISPR 32 (VCCI) CNS 13438 (BSMI)

3.2. MTBF

MTBF, Mean Time between Failures, is a measure of reliability of a device. Its value represents the average time between a repair and the next failure. The unit of MTBF is in hours. The higher the MTBF value, the higher the reliability of the device.

Our MTBF result is based on Telcorida methodology. Please note that a lower MTBF should be expected for higher capacity drives, and we apply the lowest MTBF for all capacities.

3.3. Certification & Compliance

- RoHS
- WHQL
- PCI Express Base 3.1
- UNH-IOL NVM Express Logo

4. ELECTRICAL SPECIFICATIONS



4.1. Supply Voltage

Parameter	Rating
Operating Voltage	Min = 3.14V Max = 3.47V
Rise Time (Max/Min)	100ms / 0.1ms
Fall Time (Max/Min)	5s / 1ms
Min. off Time ^{Note1}	1s

Note:

1. Minimum time between power removed from SSD (Vcc < 100mW) and power re-applied to the drive.

4.2. Power Consumption

- Power consumption with Toshiba BiCS3 TLC in mW

Capacity	Flash Structure	CE#	Read (Max)	Write (Max)	Read (Avg.)	Write (Avg.)
32GB	32GB x 1	1	1500	1300	1450	1300
64GB	32GB x 2	2	1800	1500	1800	1450
128GB	64GB x 2	4	2600	1800	2550	1800
256GB	64GB x 4	8	2900	2400	2850	2300
512GB	128GB x 4	16	3100	2600	3000	2500

Unit: mW

Notes

1. Based on E8FM1xxx-series under ambient temperature.
2. Use CrystalDiskMark 5.1.2 with the setting of 1000MB. Sequentially read and write the disk for 5 times, and measure power consumption during sequential Read [1/5]~[5/5] or sequential Write [1/5]~[5/5]
3. Power Consumption may differ according to flash configuration and platform.
4. The measured power voltage is 3.3V.

■ Power State Power consumption with Toshiba BiCS3 TLC in mW

Capacity	Flash Structure	CE#	Seq. Write			PS3	PS4
			PS0	PS1	PS2		
32GB	32GB x 1	1	1300	1300	1250	30	2
64GB	32GB x 2	2	1500	1350	1250	30	2
128GB	64GB x 2	4	1800	1600	1400	30	2
256GB	64GB x 4	8	2400	2100	1700	30	2
512GB	128GB x 4	16	2600	2200	1700	30	2

Unit: mW

Notes

1. Based on E8FM1xxx-series under ambient temperature.
2. The average value of power consumption is achieved based on 100% conversion efficiency.
3. The measured power voltage is 3.3V.
4. The temperature of a storage device in PS1 should remain constant or should slightly decrease for all workloads so the actual power in PS1 should be lower than PS0.
5. The temperature of a storage device in PS2 should decrease sharply for all workloads so the actual power in PS2 should be lower than PS1.

■ Mobile Mark 2014 Average Power consumption with Toshiba BiCS3 TLC

Capacity	Flash Structure	CE#	Primary
32GB	32GB x 1	1	< 300mW
64GB	32GB x 2	2	< 300mW
128GB	64GB x 2	4	< 300mW
256GB	64GB x 4	8	< 300mW
512GB	128GB x 4	16	< 300mW

Unit: mW

Notes

1. Based on E8FM1xxx-series under ambient temperature.
2. The measured power voltage is 3.3V.
3. The average value of power consumption is achieved based on 100% conversion efficiency.

5. INTERFACE



5.1. Pin Assignment and Descriptions

- The follow table lists the pin assignment of the media.

The I/O column indicates the signal direction viewed from the media: “I” indicates the signal input to the media and “O” indicates the signal output from the media. In the Connection column, “R” indicates the signal is required, “Opt” indicates the signal is optional, and “NC” indicates the signal shall not be connected.

Pin #	Signal	I/O	Media	Host	Notes
21	GND		R	R	
20	PETp0	I	R	R	
19	PETn0	I	R	R	
18	GND		R	R	
17	PERp0	O	R	R	
16	PERn0	O	R	R	
15	GND		R	R	
14	REFCLK+	I	R	R	
13	REFCLK-	I	R	R	
12	INS#	O	R	R	1
11	CLKREQ#	O	R	Opt	2
10	+3.3V		R	R	
9	PERST#	I	R	R	
8	Reserved		NC	NC	
7	Reserved		NC	NC	4
6	PETp1	I	Opt	Opt	
5	PETn1	I	Opt	Opt	
4	GND		R	Opt	3
3	PERp1	O	Opt	Opt	
2	PERn1	O	Opt	Opt	
1	GND		R	R	

Notes

- A host pull-up resistor in the range of 100K Ω -200K Ω is required on this pin.
- A host pull-up resistor ($\geq 5K\Omega$)
- If the PCI Express Transmitter differential pair Lane 1 and Receiver differential pair Lane 1 are implemented, this pin shall be connected to ground.
- Note that this pin is assigned to USBEN in XQD specification.

UD info CORP. TEL: +886-2-7713-6050 FAX: +886-2-8511-3151

3F-4, No.8, Ln. 609, Sec. 5, Chongxin Rd., Sanchong Dist., New Taipei City 241, Taiwan (R.O.C.)

■ Signal / Pin Descriptions

Category	Signal Name	Description
PCI Express	PETp0	PCI Express 8GT/s two Lane. 2 transmitter differential pairs and 2 receiver differential pairs.
	PETn0	
	PERp0	
	PERn0	
	PETp1	
	PETn1	
	PERp1	
	PERn1	
Auxiliary	REFCLK+	PCI Express differential (and spread-spectrum) reference clock.
	REFCLK-	
	PERST#	PCI Express functional reset.
	INS#	This signal is used for media detection and power control.
	CLKREQ#	This signal is used to indicate when REFCLK is needed for the PCI Express interface.
Power Source	+3.3V	3.3V power
Ground	GND	Ground

6. SUPPORTED COMMANDS



6.1. NVMe Command List

Table 6-1 Admin Commands

Op-Code	Command Description
00h	Delete I/O Submission Queue
01h	Create I/O Submission Queue
02h	Get Log Page
04h	Delete I/O Completion Queue
05h	Create I/O Completion Queue
06h	Identify
08h	Abort
09h	Set Features
0Ah	Get Features
0Ch	Asynchronous Event Request
10h	Firmware Activate
11h	Firmware Image Download

Table 6-2 Admin Commands – NVM Command Set Specific

Op-Code	Command Description
80h	Format NVM
81h	Security Send
82h	Security Receive

Table 6-3 NVM Commands

Op-Code	Command Description
00h	Flush
01h	Write
02h	Read
04h	Write Uncorrectable
08h	Write Zeroes
09h	Dataset Management

6.2. Identify Device Data

The following table details the sector data returned by the IDENTIFY DEVICE command.

■ Identify Controller Data Structure

Bytes	Description
01:00	PCI Vendor ID (VID)
03:02	PCI Subsystem Vendor ID (SSVID)
23:04	Serial Number (SN)
63:24	Model Number (MN)
71:64	Firmware Revision (FR)
72	Recommended Arbitration Burst (RAB)
75:73	IEEE OUI Identifier (IEEE)
76	Controller Multi-Path I/O and Namespace Sharing Capabilities (CMIC)
77	Maximum Data Transfer Size (MDTS)
79:78	Controller ID (CNTLID)
83:80	Version (VER)
87:84	RTD3 Resume Latency (RTD3R)
91:88	RTD3 Entry Latency (RTD3E)
95:92	Optional Asynchronous Events Supported (OAES)
239:96	Reserved
255:240	Refer to the NVMe Management Interface Specification for definition
257:256	Optional Admin Command Support (OACS)
258	Abort Command Limit (ACL)
259	Asynchronous Event Request Limit (AERL)
260	Firmware Updates (FRMW)
261	Log Page Attributes (LPA)
262	Error Log Page Entries (ELPE)
263	Number of Power States Support (NPSS)
264	Admin Vendor Specific Command Configuration (AVSCC)
265	Autonomous Power State Transition Attributes (APSTA)
267:266	Warning Composite Temperature Threshold (WCTEMP)
269:268	Critical Composite Temperature Threshold (CCTEMP)
271:270	Maximum Time for Firmware Activation (MTFA)
275:272	Host Memory Buffer Preferred Size (HMPRE)
279:276	Host Memory Buffer Minimum Size (HMMIN)
295:280	Total NVM Capacity (TNVMCAP)

UD info CORP. TEL: +886-2-7713-6050 FAX: +886-2-8511-3151

3F-4, No.8, Ln. 609, Sec. 5, Chongxin Rd., Sanchong Dist., New Taipei City 241, Taiwan (R.O.C.)

Bytes	Description
311:296	Unallocated NVM Capacity (UNVMCAP)
315:312	Replay Protected Memory Block Support (RPMBS)
511:316	Reserved
NVM Command Set Attributes	
512	Submission Queue Entry Size (SQES)
513	Completion Queue Entry Size (CQES)
515:514	Reserved
519:516	Number of Namespaces (NN)
521:520	Optional NVM Command Support (ONCS)
523:522	Fused Operation Support (FUSES)
524	Format NVM Attributes (FNA)
525	Volatile Write Cache (VWC)
527:526	Atomic Write Unit Normal (AWUN)
529:528	Atomic Write Unit Power Fail (AWUPF)
530	NVM Vendor Specific Command Configuration (NVSCC)
531	Reserved
533:532	Atomic Compare & Write Unit (ACWU)
535:534	Reserved
539:536	SGL Support (SGLS)
703:540	Reserved
IO Command Set Attributes	
2047:704	Reserved
2079:2048	Power State 0 Descriptor
2111:2080	Power State 1 Descriptor
2143:2112	Power State 2 Descriptor
2175:2144	Power State 3 Descriptor
2207:2176	Power State 4 Descriptor
...	N/A
3071:3040	Power State 31 Descriptor
Vendor Specific	
4095:3072	Vendor Specific (VS)

■ Identify Namespace Data Structure & NVM Command Set Specific

Bytes	Description
7:0	Namespace Size (NSZE)
15:8	Namespace Capacity (NCAP)
23:16	Namespace Utilization (NUSE)
24	Namespace Features (NSFEAT)
25	Number of LBA Formats (NLBAF)
26	Formatted LBA Size (FLBAS)
27	Metadata Capabilities (MC)
28	End-to-end Data Protection Capabilities (DPC)
29	End-to-end Data Protection Type Settings (DPS)
30	Namespace Multi-path I/O and Namespace Sharing Capabilities (NMIC)
31	Reservation Capabilities (RESCAP)
119:32	Reserved
127:120	IEEE Extended Unique Identifier (EUI64)
131:128	LBA Format 0 Support (LBAF0)
135:132	LBA Format 1 Support (LBAF1)
139:136	LBA Format 2 Support (LBAF2)
143:140	LBA Format 3 Support (LBAF3)
147:144	LBA Format 4 Support (LBAF4)
151:148	LBA Format 5 Support (LBAF5)
155:152	LBA Format 6 Support (LBAF6)
159:156	LBA Format 7 Support (LBAF7)
163:160	LBA Format 8 Support (LBAF8)
167:164	LBA Format 9 Support (LBAF9)
171:168	LBA Format 10 Support (LBAF10)
175:172	LBA Format 11 Support (LBAF11)
179:176	LBA Format 12 Support (LBAF12)
183:180	LBA Format 13 Support (LBAF13)
187:184	LBA Format 14 Support (LBAF14)
191:188	LBA Format 15 Support (LBAF15)
383:192	Reserved
4095:384	Vendor Specific (VS)

■ List of Identify Namespace Data Structure for Each Capacity

Capacity (GB)	Byte[7:0]: Namespace Size (NSZE)
30	37E90F0h
32	3BA2EB0h
60	6FCCF30h
64	7740AB0h
120	DF94BB0h
128	EE7C2B0h
240	1BF244B0h
256	1DCF32B0h
480	37E436B0h
512	3B9E12B0h



6.3. SMART Attributes

■ SMART Attributes (Log Identifier 02h)

Bytes Index	Bytes	Description
[0]	1	Critical Warning
[2:1]	2	Composite Temperature
[3]	1	Available Spare
[4]	1	Available Spare Threshold
[5]	1	Percentage Used
[31:6]	26	Reserved
[47:32]	16	Data Units Read
[63:48]	16	Data Units Written
[79:64]	16	Host Read Commands
[95:80]	16	Host Write Commands
[111:96]	16	Controller Busy Time
[127:112]	16	Power Cycles
[143:128]	16	Power On Hours
[159:144]	16	Unsafe Shutdowns
[175:160]	16	Media and Data Integrity Errors
[191:176]	16	Number of Error Information Log Entries
[195:192]	4	Warning Composite Temperature Time
[199:196]	4	Critical Composite Temperature Time
[201:200]	2	Temperature Sensor 1
[203:202]	2	Temperature Sensor 2
[205:204]	2	Temperature Sensor 3
[207:206]	2	Temperature Sensor 4

7. PHYSICAL DIMENSION



Dimension: 38.5mm(L) x 29.6mm(W) x 3.8mm(H)

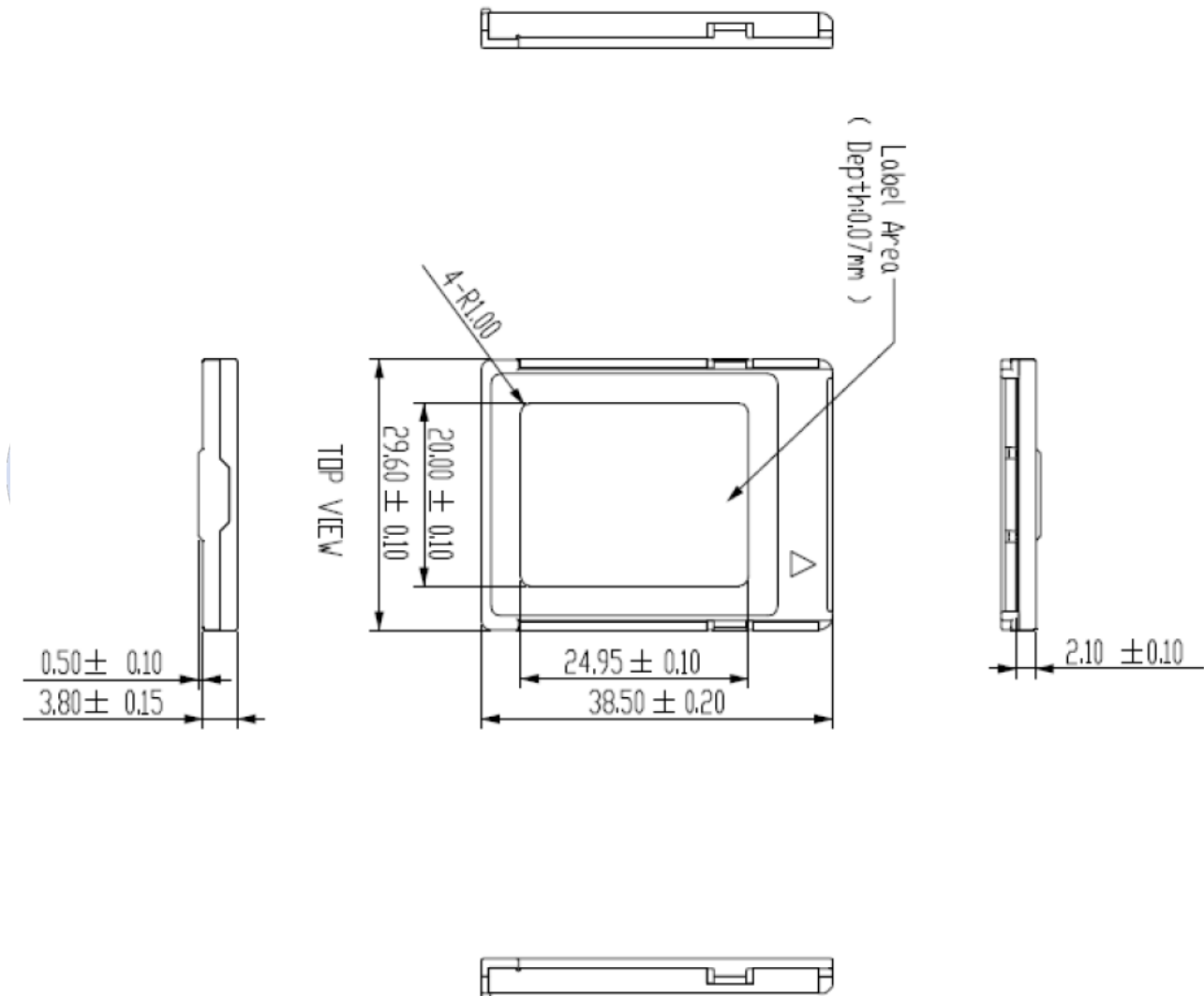

8. TERMINOLOGY



The following table is to list out the acronyms that have been applied throughout the document.

Term	Definitions
ATTO	Commercial performance benchmark application
DDR	Double data rate (SDRAM)
ASPM	Active States Power Management
APST	Autonomous Power State Transition
LBA	Logical block addressing
MTBF	Mean time between failures
PCIe	PCI Express / Peripheral Component Interconnect Express
S.M.A.R.T.	Self-monitoring, analysis and reporting technology

9. BARCODE DESCRIPTION



C F X 2 1 U F 5 1 2 G B A D P

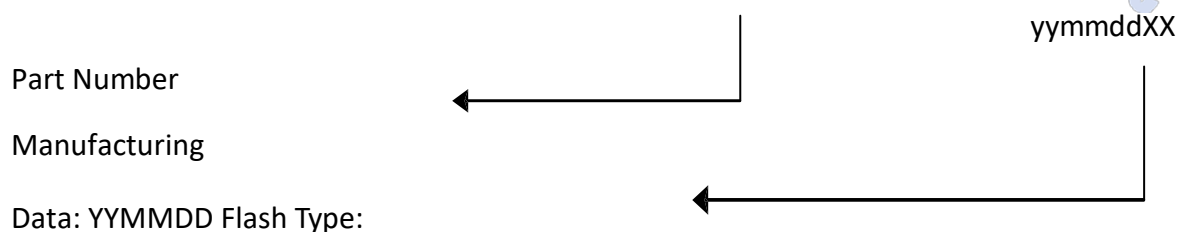

10. PARTNUMBER DECODER



CFX-21UFX⁸X⁹X¹⁰X¹¹X¹²X¹³X¹⁴X¹⁵X¹⁶X¹⁷

X ¹ X ² X ³	X ⁴ X ⁵	X ⁶ X ⁷	X ⁸ X ⁹ X ¹⁰ X ¹¹ X ¹²	X ¹³	X ¹⁴	X ¹⁵	X ¹⁶ X ¹⁷
CFX	21	UF	32GB 64GB 128GB 256GB 512GB	A: 3D TLC Standard (0°C ~ +70°C)	D	P	blank

