

UD info Corp.

Industrial SATA Solid State Drive HF3-25UF Series Product DataSheet

Preliminary Version

UD info CORP.

3F-4, No.8, Ln. 609, Sec. 5, Chongxin Rd., Sanchong Dist., New Taipei City 241, Taiwan (R.O.C.)

TEL: +886-2-7713-6050 FAX: +886-2-8511-3151

E-mail: sales@UDinfo.com.tw

1.	Introduction	5
1.1.	General Description	5
1.2.	Block Diagram	5
2.	Product Specifications.....	6
3.	Environmental Specifications	8
3.1.	Environmental Conditions	8
3.1.1.	Temperature and Humidity	8
3.1.2.	Shock.....	9
3.1.3.	Vibration.....	9
3.1.4.	Drop	9
3.1.5.	Bending	9
3.1.6.	Electrostatic Discharge (ESD)	9
3.1.7.	EMI Compliance	9
3.2.	MTBF.....	10
3.3.	Certification	10
3.4.	Compliance	10
4.	Electrical Specifications	11
4.1.	Supply Voltage.....	11
4.2.	Power Consumption.....	11
5.	Interface.....	12
5.1.	Pin Assignment and Descriptions	12
6.	Supported Commands.....	13
6.1.	ATA Command List.....	13
6.2.	Identify Device Data	18
7.	Physical Dimension	22
8.	Terminology	23
9.	Barcode description	23
10.	Partnumber decoder	24

Revision History

Revision	Draft Date	History	Author
1.0	2018/12/4	New release	Golden Lee



Product Overview

- **Capacity**
 - 240GB up to 3840GB
- **Form Factor**
 - 2.5" SATA SSD
- **SATA Interface**
 - SATA Revision 3.2
 - SATA 1.5Gbps, 3Gbps, and 6Gbps interface
- **Flash Interface**
 - Flash Type: 3D Bics3 TLC
 - Up to 8pcs of BGA132/152 flash
- **Performance**
 - Read up to 550 MB/s
 - Write up to 530 MB/s
- **Power Consumption**^{Note1}
 - Idle mode: < 910 mW
- **Advanced Flash Management**
 - Static and Dynamic Wear Leveling
 - Bad Block Management
 - TRIM
 - SMART
 - Over-Provision
- **Low Power Management**
 - DIPM/HIPM Mode
 - DEVSLP Mode (Optional)
- **Temperature Range**
 - Operation (Standard): 0°C ~ 70°C
 - Operation (Wide): -40°C ~ 85°C
 - Storage: -40°C ~ 85°C
 - Operation airflow: 800 LFM at 35C ambient
- **Compliant**
 - RoHS
 - CE & FCC
- **Features Support List:**
 - End to end data path protection
 - Thermal throttling
 - SmartECC™
 - SmartRefresh™
 - Drive log
 - Support of AES/TCG OPAL^{Note2}

Notes:

1. Please see "Power Consumption" for details.
2. Supported by separate firmware version. Further information available upon request.

1. INTRODUCTION

1.1. General Description

UDinfo 2.5" SATA SSD delivers all the advantages of flash disk technology with Serial ATA I/II/III interface, including being fully compliant with standard 2.5-inch form factor, providing low power consumption compared to traditional hard drive and hot-swapping when removing/replacing/upgrading flash disks. The device is designed based on the standard 7-pin interface for data segment and 15-pin for power segment, as well as operating at a maximum operating frequency of 400MHz with 25MHz external crystal. Its capacity could provide a wide range up to 4TB. Moreover, it can reach up to 550MB/s read as well as 530MB/s write high performance based on Toshiba's 3D TLC NAND flash.

1.2. Block Diagram

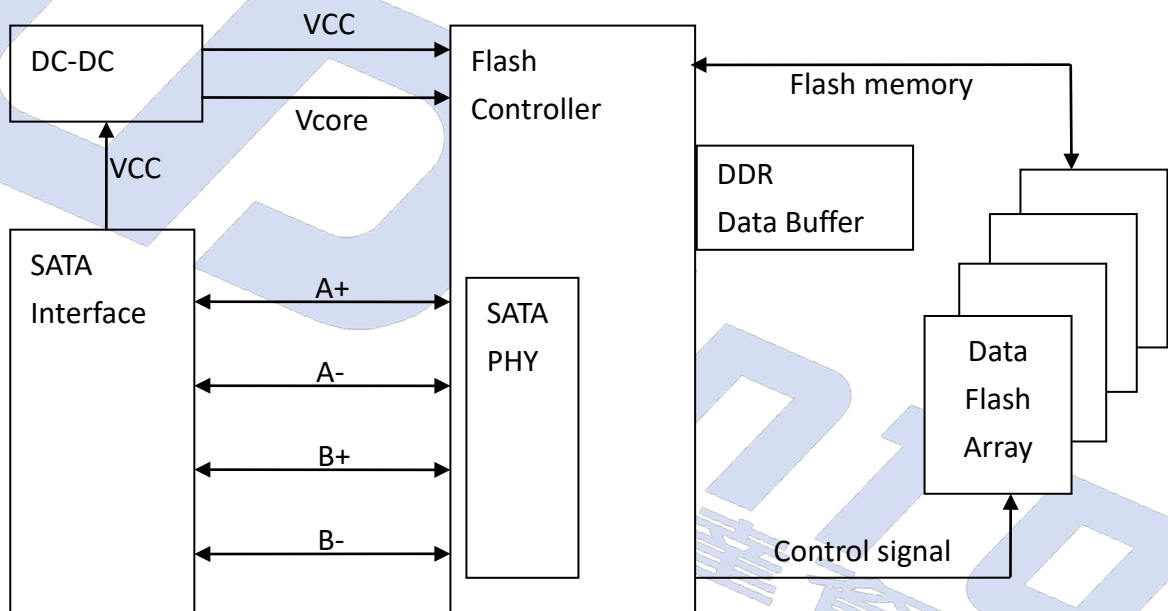

2.5" SATA SSD Block Diagram

Notes:

1. Achieved by 960/1024GB SSD with external 1GB DDR3L at FOB (fresh-out-box) state on CrystalDiskMark v5.1.2.
2. The choice of DDR3L depends on drive capacity; DDR size = 0.1% of SSD capacity.

2. PRODUCT SPECIFICATIONS



- **Capacity**
 - From 240GB up to 3840GB
 - Optional for over-provision
- **Electrical/Physical Interface**
 - SATA Interface
 - ◆ Compliant with SATA Revision 3.2
 - ◆ Compatible with SATA 1.5Gbps, 3Gbps and 6Gbps interface
 - ◆ Support power management
 - ◆ Support expanded register for SATA protocol 48 bits addressing mode
 - ◆ Embedded BIST function for SATA PHY for low cost mass production
- **Supported NAND Flash**
 - Support up to 32 Flash Chip Enables (CE) within single design
 - Support 8pcs BGA132/152 flash
 - Support OFNI 4.0 & Toggle 2.0 interface: 8 channels at maximum
 - Support Toshiba 3D Bics3 TLC
- **ECC Scheme**
 - Applies the LDPC (Low Density Parity Check) of ECC algorithm
- **UART / GPIO function**
- **Support SMART and TRIM commands**
- **Capacity Information**

Capacity	Cylinders	Heads	Sectors	Total Sectors	User Data Size
240GB	16,383	16	63	468,862,128	Depended on file management
480GB	16,383	16	63	937,703,088	
960GB	16,383	16	63	1,875,385,008	
1920GB	16,383	16	63	3,750,748,848	
3840GB	16,383	16	63	7,501,476,528	

- Performance (Est.)

- 3D Bics3:

Capacity	Flash Structure	Flash Type	Sequential	
			Read (MB/s)	Write (MB/s)
240GB	64GB x 4	TSB Bics3, BGA	550	530
480GB	64GB x 8 128GB x 4	TSB Bics3, BGA	550	530
960GB	128GB x 8	TSB Bics3, BGA	550	530
1920GB	128GB x 16 256GB x 8	TSB Bics3, BGA	550	530
3840GB	256GB x 16	TSB Bics3, BGA	550	530

Notes:

1. The performance was measured CrystalDiskMark5.0x64 with SATA 6Gbps host and test data size is 1GB
2. The performance was estimated based on Toshiba BiCS3 TLC NAND flash.
3. Performance may differ according to flash configuration and platform.
4. The table above is for reference only. The criteria for MP (Mass Production) and for accepting goods shall be discussed based on different flash configuration.

- TBW (Terabytes Written)

- 3D Bics3:

Capacity	Flash Type	TBW
240GB	TSB Bics3	375
480GB	TSB Bics3	750
960GB	TSB Bics3	1500
1920GB	TSB Bics3	3000
3840GB	TSB Bics3	6000

Notes:

1. Samples were built using Toshiba BiCS3 TLC NAND flash.
2. The test followed JEDEC219A client endurance workload.
3. TBW may differ according to flash configuration and platform.
4. The endurance of SSD could be estimated based on user behavior, NAND endurance cycles, and write amplification factor. It is not guaranteed by flash vendor.

3. ENVIRONMENTAL SPECIFICATIONS



3.1. Environmental Conditions

3.1.1. Temperature and Humidity

- Temperature:
 - ◆ Storage: -40°C to 85°C
 - ◆ Operational (Standard grade): 0°C to 70°C
 - ◆ Operational (Wide grade): -40°C to 85°C

■ High Temperature Test Condition

	Temperature	Humidity
Operation	70°C / 85°C	0% RH
Storage	85°C	0% RH

■ Low Temperature Test Condition

	Temperature	Humidity
Operation	0°C / -40°C	0% RH
Storage	-40°C	0% RH

■ High Humidity Test Condition

	Temperature	Humidity
Operation (Standard)	40°C	90% RH
Storage (Standard)	40°C	93% RH

■ Temperature Cycle Test

	Temperature
Operation	0°C / -40°C
	70°C / 85°C
Storage	-40°C
	85°C

Notes:

1. Operation temperature is measured by device temperature sensor. Airflow is suggested and it will allow device to be operated at appropriate temperature for each component during heavy workloads environment.
2. Operation temperature shows in case temperature not ambient temperature.

3.1.2. Shock

■ Shock Specification

	Acceleration Force
Non-operational	1500G

3.1.3. Vibration

■ Vibration Specification

	Condition	
	Frequency/Displacement	Frequency/Acceleration
Non-operational	20Hz~80Hz/1.52mm	80Hz~2000Hz/20G

3.1.4. Drop

■ Drop Specification

	Height of Drop	Number of Drop
Non-operational	80cm free fall	6 face of each unit

3.1.5. Bending

■ Bending Specification

	Force	Action
Non-operational	≥ 20N	Hold 1min/5times

3.1.6. Electrostatic Discharge (ESD)

■ Contact ESD Specification

Specification	+/- 4KV
EN 55024, CISPR 24 EN 61000-4-2 and IEC 61000-4-2	Device functions are affected, but EUT will be back to its normal or operational state automatically.

3.1.7. EMI Compliance

Specification
EN 55032, CISPR 32 (CE) AS/NZS CISPR 32 (CE) ANSI C63.4 (FCC) VCCI-CISPR 32 (VCCI) CNS 13438 (BSMI)

3.2. MTBF

MTBF, an acronym for Mean Time between Failures, is a measure of reliability of a device. Its value represents the average time between a repair and the next failure. The unit of MTBF is in hours. The higher the MTBF value, the higher the reliability of the device. The predicted result of UDinfo's 2.5" SATA SSD is up to 2,000,000 hours.

Our MTBF result is based on simulation software (Relux 7.3). Please note that a lower MTBF should be expected for higher capacity drives, and we apply the lowest MTBF for all capacities.

3.3. Certification

- RoHS
- CE / FCC

3.4. Compliance

- SATA III (SATA Rev. 3.2)
- Up to ATA/ATAPI-8 (Including S.M.A.R.T)

4. ELECTRICAL SPECIFICATIONS



4.1. Supply Voltage

Parameter	Rating
Operating Voltage	5V ± 5% (4.75V~5.25V)

4.2. Power Consumption

■ 3D Bics3

Capacity	Flash Structure	Flash Type	CE#	Read	Write	Partial	Slumber	Idle
240GB	64GB x 4	TSB Bics3, BGA	8	2200	2400	265	70	370
480GB	64GB x 8 128GB x 4	TSB Bics3, BGA	16	2400	2500	275	70	370
960GB	128GB x 8	TSB Bics3, BGA	32	2500	2600	275	210	370
1920GB	128GB x 16 256GB x 8	TSB Bics3, BGA	32	TBD	TBD	TBD	TBD	TBD
3840GB	256GB x 16	TSB Bics3, BGA	64	TBD	TBD	TBD	TBD	TBD

Unit: mW

Notes:

1. The average value of power consumption is achieved based on 100% conversion efficiency.
2. The measured power voltage is 5V.
3. Samples were built using Toshiba BiCS3 TLC NAND flash and measured under normal temperature.
4. Sequential R/W is measured while testing 1GB sequential R/W 5 times by CrystalDiskMark.
5. Power Consumption may differ according to flash configuration and platform.

5. INTERFACE



5.1. Pin Assignment and Descriptions

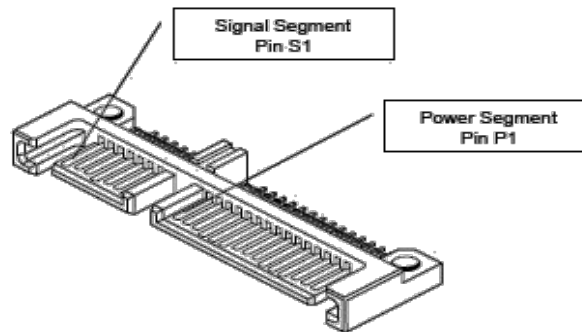

- Signal Segment Pin Assignment and Description

Pin Number	Function
S1	GND
S2	A+ (Differential Signal Pair A)
S3	A – (Differential Signal Pair A)
S4	GND
S5	B – (Differential Signal Pair B)
S6	B+ (Differential Signal Pair B)
S7	GND

- Power Segment Pin Assignment and Description

Pin Number	Function
P1	Not Used (3.3V)
P2	Not Used (3.3V)
P3	DEVSLP
P4	GND
P5	GND
P6	GND
P7	5V pre-charge
P8	5V
P9	5V
P10	GND
P11	Reserved
P12	GND
P13	Not Used (12V pre-charge)
P14	Not Used (12V)
P15	Not Used (12V)

6. SUPPORTED COMMANDS



6.1. ATA Command List

Op Code	Support	Description	Op Code	Support	Description	
00h	Y	NOP	B6h	12h	-	NV Cache: QUERY NV CACHE PINNED SET DMA EXT
03h	-	CFA REQUEST EXTENDED ERROR	B6h	13h	-	NV Cache: QUERY NV CACHE MISSES DMA EXT
06h	Y	DATA SET MANAGEMENT	B6h	14h	-	NV Cache: FLUSH NV CACHE
08h	-	DEVICE RESET	C4h		Y	READ MULTIPLE
0Bh	-	REQUEST SENSE DATA EXT	C5h		Y	WRITE MULTIPLE
10h	Y	RECALIBRATE	C6h		Y	SET MULTIPLE MODE
11h-1Fh	-	RECALIBRATE	C7h		-	READ DMA QUEUED
20h	Y	READ SECTOR(S)	C8h		Y	READ DMA
21h	Y	READ SECTOR(S) WITHOUT RETRY	C9h		Y	READ DMA WITHOUT RETRY
22h	-	READ LONG	CAh		Y	WRITE DMA
23h	-	READ LONG WITHOUT RETRY	CBh		Y	WRITE DMA WITHOUT RETRY
24h	Y	READ SECTOR(S) EXT	CCh		-	WRITE DMA QUEUED
25h	Y	READ DMA EXT	CDh		-	CFA WRITE MULTIPLE WITHOUT ERASE
26h	-	READ DMA QUEUED EXT	CEh		Y	WRITE MULTIPLE FUA EXT
27h	Y	READ NATIVE MAX ADDRESS EXT	D1h		-	CHECK MEDIA CARD TYPE
29h	Y	READ MULTIPLE EXT	DAh		-	GET MEDIA STATUS
2Ah	-	READ STREAM DMA EXT	DEh		-	MEDIA LOCK
2Bh	-	READ STREAM EXT	DFh		-	MEDIA UNLOCK
2Fh	Y	READ LOG EXT	E0h		Y	STANDBY IMMEDIATE
30h	Y	WRITE SECTOR(S)	E1h		Y	IDLE IMMEDIATE
31h	Y	WRITE SECTOR(S) WITHOUT RETRY	E2h		Y	STANDBY
32h	-	WRITE LONG	E3h		Y	IDLE
33h	-	WRITE LONG WITHOUT RETRY	E4h		Y	READ BUFFER
34h	Y	WRITE SECTOR(S) EXT	E5h		Y	CHECK POWER MODE
35h	Y	WRITE DMA EXT	E6h		Y	SLEEP
36h	-	WRITE DMA QUEUED EXT	E7h		Y	FLUSH CACHE
37h	Y	SET MAX ADDRESS EXT	E8h		Y	WRITE BUFFER

UD info CORP. TEL: +886-2-7713-6050 FAX: +886-2-8511-3151

3F-4, No.8, Ln. 609, Sec. 5, Chongxin Rd., Sanchong Dist., New Taipei City 241, Taiwan (R.O.C.)

Op Code	Support	Description	Op Code	Support	Description		
38h	-	CFA WRITE SECTORS WITHOUT ERASE	E9h	Y	READ BUFFER DMA		
39h	Y	WRITE MULTIPLE EXT	EAh	Y	FLUSH CACHE EXT		
3Ah	-	WRITE STREAM DMA EXT	EBh	Y	WRITE BUFFER DMA		
3Bh	-	WRITE STREAM EXT	ECh	Y	IDENTIFY DEVICE		
3Ch	-	WRITE VERIFY	EDh	-	MEDIA EJECT		
3Dh	Y	WRITE DMA FUA EXT	EEh	-	IDENTIFY DEVICE DMA		
3Eh	-	WRITE DMA QUEUED FUA EXT	EFh	01h	-	SET FEATURES: Enable 8-bit PIO transfer mode (CFA feature set only)	
3Fh	Y	WRITE LOG EXT	EFh	02h	Y	SET FEATURES: Enable write cache	
40h	Y	READ VERIFY SECTOR(S)	EFh	03h	Y	SET FEATURES: Set transfer mode based on value in Count field	
41h	Y	READ VERIFY SECTOR(S) WITHOUT RETRY	EFh	05h	Y	SET FEATURES: Enable advanced power management	
42h	Y	READ VERIFY SECTOR(S) EXT	EFh	06h	-	SET FEATURES: Enable Power-Up In Standby feature set	
44h	-	Reserved	EFh	07h	-	SET FEATURES: Power-Up In Standby feature set device spin-up	
45h	O	WRITE UNCORRECTABLE EXT	EFh	0Ah	-	SET FEATURES: Enable CFA power mode 1	
47h	Y	READ LOG DMA EXT	EFh	0Bh	-	SET FEATURES: Enable Write-Read-Verify feature set	
50h	-	FORMAT TRACK	EFh	10h	01h	-	SET FEATURES: Enable use of Serial ATA feature
51h	-	CONFIGURE STREAM	EFh	10h	02h	Y	SET FEATURES: Enable DMA Setup FIS Auto-Activate optimization
57h	Y	WRITE LOG DMA EXT	EFh	10h	03h	Y	SET FEATURES: Enable Device-initiated interface power state (DIPM) transitions
60h	Y	READ FPDMA QUEUED	EFh	10h	04h	-	SET FEATURES: Enable use of Serial ATA feature
61h	Y	WRITE FPDMA QUEUED	EFh	10h	05h	-	SET FEATURES: Enable use of Serial ATA feature
70h	Y	SEEK	EFh	10h	06h	O	SET FEATURES: Enable Software Settings Preservation (SSP)

UD info CORP. TEL: +886-2-7713-6050 FAX: +886-2-8511-3151

3F-4, No.8, Ln. 609, Sec. 5, Chongxin Rd., Sanchong Dist., New Taipei City 241, Taiwan (R.O.C.)

Op Code	Support	Description	Op Code	Support	Description
71-76h	-	SEEK	EFh 10h 07h	Y	SET FEATURES: Enable Device Automatic Partial to Slumber transitions
77h	Y	SET DATE AND TIME EXT	EFh 10h 09h	O	SET FEATURES: Enable Device Sleep
78h	Y	ACCESSIBLE MAX ADDRESS CONFIGURATION	EFh 42h	-	SET FEATURES: Enable Automatic Acoustic Management feature set
79-7Fh	-	SEEK	EFh 43h	-	SET FEATURES: Set Maximum Host Interface Sector Times
87h	-	CFA TRANSLATE SECTOR	EFh 44h	-	SET FEATURES: Vendor Specific ECC byte
90h	Y	EXECUTE DEVICE DIAGNOSTIC	EFh 55h	Y	SET FEATURES: Disable read look-ahead feature
91h	Y	INITIALIZE DEVICE PARAMETERS	EFh 5Dh	-	SET FEATURES: Enable release interrupt
92h	Y	DOWNLOAD MICROCODE	EFh 5Eh	-	SET FEATURES: Enable service interrupt
93h	Y	DOWNLOAD MICROCODE DMA	EFh 5Fh	-	SET FEATURES: Enable NDRQ Feature
94h	-	STANDBY IMMEDIATE	EFh 66h	Y	SET FEATURES: Disable reverting to power-on defaults
95h	-	IDLE IMMEDIATE	EFh 81h	-	SET FEATURES: Disable 8-bit PIO transfer mode (CFA feature set only)
96h	-	STANDBY	EFh 82h	Y	SET FEATURES: Disable write cache
97h	-	IDLE	EFh 85h	Y	SET FEATURES: Disable advanced power management
98h	-	CHECK POWER MODE	EFh 86h	-	SET FEATURES: Disable Power-Up In Standby feature set
99h	-	SLEEP	EFh 8Ah	-	SET FEATURES: Disable CFA power mode
A0h	-	PACKET	EFh 8Bh	-	SET FEATURES: Disable Write-Read-Verify feature set
A1h	-	IDENTIFY PACKET DEVICE	EFh 90h 01h	-	SET FEATURES: Disable use of Serial ATA feature
A2h	-	SERVICE	EFh 90h 02h	Y	SET FEATURES: Disable DMA Setup FIS Auto-Activate optimization

UD info CORP. TEL: +886-2-7713-6050 FAX: +886-2-8511-3151

3F-4, No.8, Ln. 609, Sec. 5, Chongxin Rd., Sanchong Dist., New Taipei City 241, Taiwan (R.O.C.)

Op Code		Support	Description	Op Code		Support	Description
B0h	D0h	Y	SMART: READ DATA	EFh	90h 03h	Y	SET FEATURES: Disable Device-initiated interface power state (DIPM) transitions
B0h	D1h	Y	SMART: READ ATTRIBUTE THRESHOLDS	EFh	90h 04h	-	SET FEATURES: Disable use of Serial ATA feature
B0h	D2h	Y	SMART: ENABLE/DISABLE AUTOSAVE	EFh	90h 05h	-	SET FEATURES: Disable use of Serial ATA feature
B0h	D3h	Y	SMART: SAVE ATTRIBUTE VALUES	EFh	90h 06h	Y	SET FEATURES: Disable Software Settings Preservation (SSP)
B0h	D4h	Y	SMART: EXECUTE OFF-LINE IMMEDIATE	EFh	90h 07h	Y	SET FEATURES: Disable Device Automatic Partial to Slumber transitions
B0h	D5h	Y	SMART: READ LOG	EFh	90h 09h	0	SET FEATURES: Disable Device Sleep
B0h	D6h	Y	SMART: WRITE LOG	EFh	AAh	Y	SET FEATURES: Enable read look-ahead feature
B0h	D8h	Y	SMART: ENABLE OPERATIONS	EFh	BBh	-	SET FEATURES: Default ECC byte
B0h	D9h	Y	SMART: DISABLE OPERATIONS	EFh	C2h	-	SET FEATURES: Disable Automatic Acoustic Management feature set
B0h	DAh	Y	SMART: RETURN STATUS	EFh	C3h	-	SET FEATURES: Enable/Disable the Sense Data Reporting feature set
B0h	DBh	Y	SMART: ENABLE/DISABLE AUTOMATIC OFF-LINE	EFh	CCh	Y	SET FEATURES: Enable reverting to power-on defaults
B0h	E0h	-	SMART: Vendor specific	EFh	DDh	-	SET FEATURES: Disable release interrupt
B1h	C0h	Y	DEVICE CONFIGURATION: RESTORE	EFh	DEh	-	SET FEATURES: Disable SERVICE interrupt
B1h	C1h	Y	DEVICE CONFIGURATION: FREEZE LOCK	EFh	DFh	-	SET FEATURES: Disable NDRQ Feature
B1h	C2h	Y	DEVICE CONFIGURATION: IDENTIFY	F1h		Y	SECURITY SET PASSWORD
B1h	C3h	Y	DEVICE CONFIGURATION: SET	F2h		Y	SECURITY UNLOCK
B1h	C4h	Y	DEVICE CONFIGURATION: IDENTIFY DMA	F3h		Y	SECURITY ERASE PREPARE
B1h	C5h	Y	DEVICE CONFIGURATION: SET DMA	F4h		Y	SECURITY ERASE UNIT

Op Code		Support	Description	Op Code		Support	Description
B4h	0000h	O	SANITIZE DEVICE: SANITIZE STATUS EXT	F5h		Y	SECURITY FREEZE LOCK
B4h	0011h	O	SANITIZE DEVICE: CRYPTO SCRAMBLE EXT	F6h		Y	SECURITY DISABLE PASSWORD
B4h	0012h	O	SANITIZE DEVICE: BLOCK ERASE EXT	F8h		Y	READ NATIVE MAX ADDRESS
B4h	0014h	O	SANITIZE DEVICE: OVERWRITE EXT	F9h	00h	Y	SET MAX: SET MAX ADDRESS
B4h	0020h	O	SANITIZE DEVICE: SANITIZE FREEZE LOCK EXT	F9h	01h	Y	SET MAX: SET MAX PASSWORD
B4h	0040h	O	SANITIZE DEVICE: SANITIZE ANTIFREEZE LOCK EXT	F9h	02h	Y	SET MAX: SET MAX LOCK
B6h	00h	-	NV Cache: SET NV CACHE POWER MODE EXT	F9h	03h	Y	SET MAX: SET MAX UNLOCK
B6h	01h	-	NV Cache: RETURN FROM NV CACHE POWER MODE EXT	F9h	04h	Y	SET MAX: SET MAX FREEZE LOCK
B6h	10h	-	NV Cache: ADD LBA(S) TO NV CACHE PINNED SET DMA EXT	F9h	05h	Y	SET MAX: SET MAX SET PASSWORD DMA
B6h	11h	-	NV Cache: REMOVE LBA(S) FROM NV CACHE PINNED SET DMA EXT	F9h	06h	Y	SET MAX: SET MAX UNLOCK DMA

Notes:

“Y” means “Support”.

“O” means “Option, default not support”.

“-” means “Not support”.

6.2. Identify Device Data

The following table details the sector data returned by the IDENTIFY DEVICE command.

Word	F: Fixed V: Variable X: retired/obsolete /reserved	Default Value	Description
0	F	0040h	General configuration bit-significant information
1	X	*1	Obsolete – Number of logical cylinders
2	F	C837h	Specific configuration
3	X	0010h	Obsolete – Number of logical heads (16)
4-5	X	00000000h	Retired
6	X	003Fh	Obsolete – Number of logical sectors per logical track (63)
7-8	X	00000000h	Reserved for assignment by the Compact Flash Association
9	X	0000h	Retired
10-19	V	Varies	Serial number (20 ASCII characters)
20-21	X	0000h	Retired
22	X	0000h	Obsolete
23-26	V	Varies	Firmware revision (8 ASCII characters)
27-46	V	Varies	Model number (xxxxxxxx)
47	F	8010h	7:0- Maximum number of sectors transferred per interrupt on MULTIPLE commands
48	F	4000h	Reserved
49	F	2F00h	Capabilities
50	F	4000h	Capabilities
51-52	X	000000000h	Obsolete
53	F	0007h	Words 88 and 70:64 valid
54	X	*1	Obsolete – Number of logical cylinders
55	X	0010h	Obsolete – Number of logical heads (16)
56	X	003Fh	Obsolete – Number of logical sectors per track (63)
57-58	X	*2	Obsolete – Current capacity in sectors
59	F	0110h	Number of sectors transferred per interrupt on MULTIPLE commands
60-61	V	*3	Maximum number of sector (28bit LBA mode)
62	X	0000h	Obsolete
63	F	0407h	Multi-word DMA modes supported/selected

UD info CORP. TEL: +886-2-7713-6050 FAX: +886-2-8511-3151

3F-4, No.8, Ln. 609, Sec. 5, Chongxin Rd., Sanchong Dist., New Taipei City 241, Taiwan (R.O.C.)

Word	F: Fixed V: Variable X: retired/obsolete /reserved	Default Value	Description
64	F	0003h	PIO modes supported
65	F	0078h	Minimum Multiword DMA transfer cycle time per word
66	F	0078h	Manufacturer's recommended Multiword DMA transfer cycle time
67	F	0078h	Minimum PIO transfer cycle time without flow control
68	F	0078h	Minimum PIO transfer cycle time with IORDY flow control
69	F	1F00h	Additional Supported
70	X	0000h	Reserved
71-74	X	000000000000 0000h	Reserved for the IDENTIFY PACKET DEVICE command
75	F	001Fh	Queue depth
76	F	850Eh	Serial SATA capabilities
77	F	0006h	Supported Serial ATA Phy speed
78	F	004Ch	Serial ATA features supported
79	F	0040H	Serial ATA features enabled
80	F	0FF8h	Major Version Number
81	F	0000h	Minor Version Number
82	F	746Bh	Command set supported
83	F	7D01h	Command set supported
84	F	4163h	Command set/feature supported extension
85	F	7469h	Command set/feature supported or enabled
86	F	BC01h	Command set/feature supported or enabled
87	F	4163h	Command set/feature supported or enabled
88	F	007Fh	Ultra DMA Modes
89	F	000Ah	Time required for Normal Erase mode SECURITY ERASE UNIT command
90	F	001Eh	Time required for an Enhanced Erase mode SECURITY ERASE UNIT command
91	F	0000h	Current advanced power management value
92	F	FFFEh	Master Password Revision Code
93	F	0000h	Hardware reset result. The contents of the bits (12:0) of this word can be changed only during the execution of hardware

Word	F: Fixed V: Variable X: retired/obsolete /reserved	Default Value	Description
			reset.
94	X	0000h	Vendor's recommended and actual acoustic management value
95	F	0000h	Stream Minimum Request Size
96	F	0000h	Streaming Transfer Time – DMA
97	F	0000h	Streaming Access Latency – DMA and PIO
98-99	F	0000h	Streaming Performance Granularity
100-103	V	*4	Maximum user LBA for 48 bit Address feature set
104	F	0000h	Streaming Transfer Time – PIO
105	F	0008h	Maximum number of 512-byte blocks per DATA SET MANAGEMENT command
106	F	4000h	Physical sector size/Logical sector size
107	F	0000h	Inter-seek delay for ISO-7779 acoustic testing in microseconds
108-111	F	Varies	Reserved
112-115	X	000000000000 0000h	Reserved
116	X	0000h	Reserved
117-118	F	00000000h	Words per logical Sector
119	F	401Ch	Supported settings
120	F	401Ch	Command set/Feature Enabled/Supported
121-126	X	0h	Reserved
127	X	0h	Obsolete
128	F	0021h	Security status
129-159	V	Varies	Vendor specific
160	X	0h	Compact Flash Association (CFA) power mode 1
161-167	X	0h	Reserved for assignment by the CFA
168	V	Varies	Device Nominal Form Factor
169	F	0001h	DATA SET MANAGEMENT command is supported
170-173	F	0h	Additional Product Identifier
174-175	X	0h	Reserve
176-205	F	0h	Current media serial number
206	F	0039h	SCT Command Transport{

Word	F: Fixed V: Variable X: retired/obsolete /reserved	Default Value	Description
207-208	X	0h	Reserved
209	F	4000h	Alignment of logical blocks within a physical block
210-211	F	0000h	Write-Read-Verify Sector Count Mode 3 (not support)
212-213	F	0000h	Write-Read-Verify Sector Count Mode 2 (not support)
214-216	X	0000h	NV Cache relate (not support)
217	F	0001h	Non-rotating media device
218	X	0h	Reserved
219	X	0h	NV Cache relate (not support)
220	V	0h	Write read verify feature set current mode
221	X	0h	Reserved
222	F	10FFh	Transport major version number
223	F	0h	Transport minor version number
224-229	X	0h	reserved
230-233	F	0h	Extend number of user addressable sectors
234	F	0001h	Minimum number of 512-byte data blocks per DOWNLOAD MICROCODE command for mode 03h
235	F	FFFEh	Maximum number of 512-byte data blocks per DOWNLOAD MICROCODE command for mode 03h
236-242	X	0h	Reserved
243	X	0000h	Reserved
244-254	X	0h	Reserved
255	F	XXA5h XX is variable	Integrity word (Checksum and Signature)

■ List of Device Identification for Each Capacity

Capacity (GB)	*1 (Word 1/Word 54)	*2 (Word 57-58)	*3 (Word 60-61)	*4 (Word 100-103)
240	3FFFh	FBFC10h	0FFFFFFFh	1BF244B0h
480	3FFFh	FBFC10h	0FFFFFFFh	37E436B0
960	3FFFh	FBFC10h	0FFFFFFFh	6FC81AB0h
1920	3FFFh	FBFC10h	0FFFFFFFh	DF8FE2B0h
3840	3FFFh	FBFC10h	0FFFFFFFh	1BF1F72B0h

7. PHYSICAL DIMENSION



Dimension: 100.10mm(L) x 69.85mm(W) x 7.00mm(H)

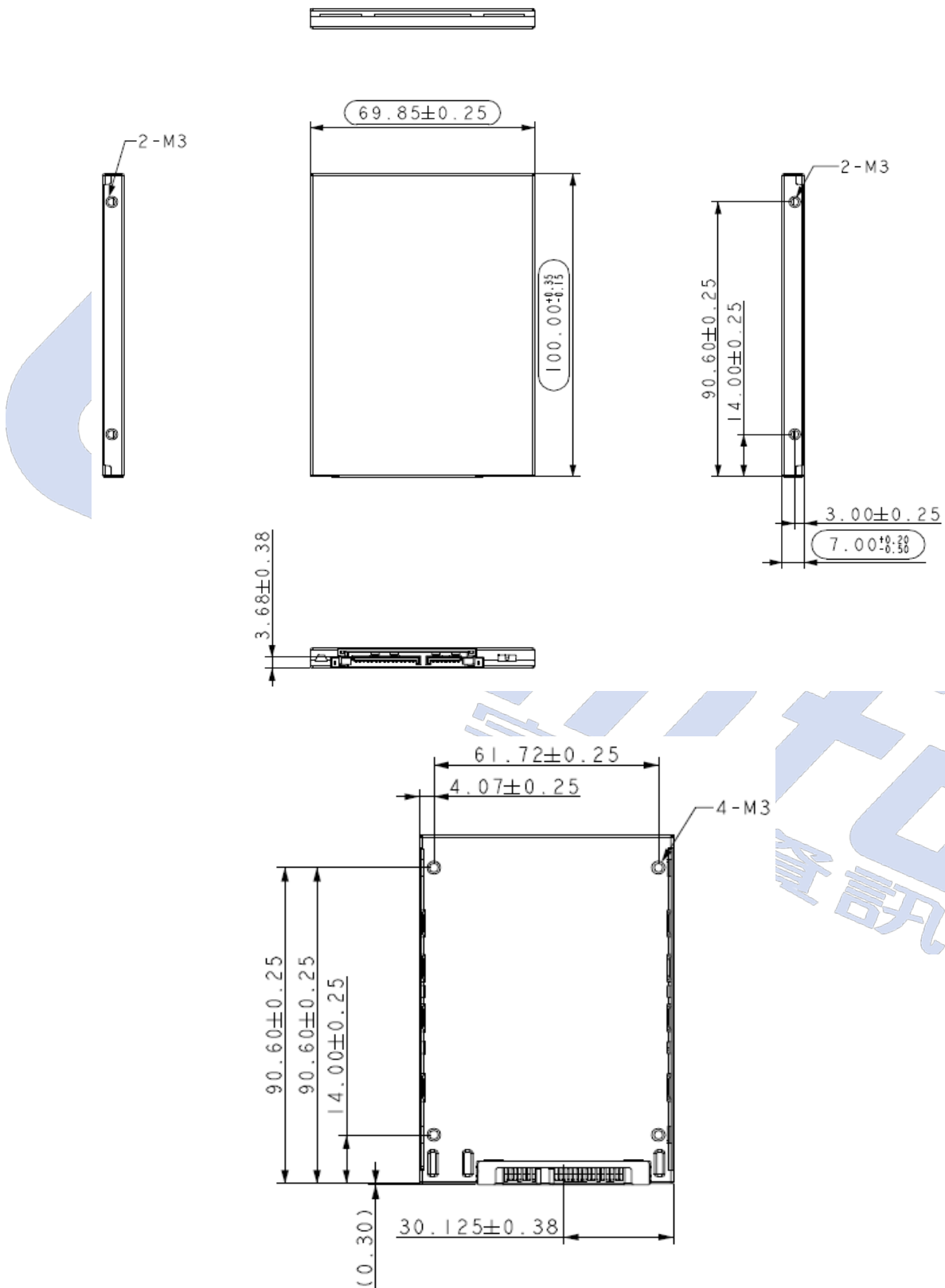

UD info CORP. TEL: +886-2-7713-6050 FAX: +886-2-8511-3151

3F-4, No.8, Ln. 609, Sec. 5, Chongxin Rd., Sanchong Dist., New Taipei City 241, Taiwan (R.O.C.)

8. TERMINOLOGY



The following table is to list out the acronyms that have been applied throughout the document.

Term	Definitions
ATTO	Commercial performance benchmark application
DDR	Double data rate (SDRAM)
DIPM	Device initiated power management
HIPM	Host initiated power management
LBA	Logical block addressing
MB	Mega-byte
MTBF	Mean time between failures
NCQ	Native command queue
SATA	Serial advanced technology attachment
S.M.A.R.T.	Self-monitoring, analysis and reporting technology
SSD	Solid state disk

9. BARCODE DESCRIPTION

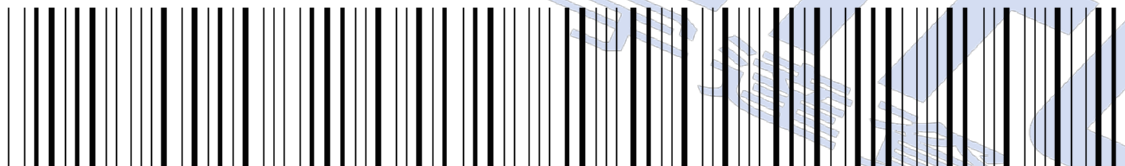

H F 3 2 5 U F 9 6 0 G B A 8 P

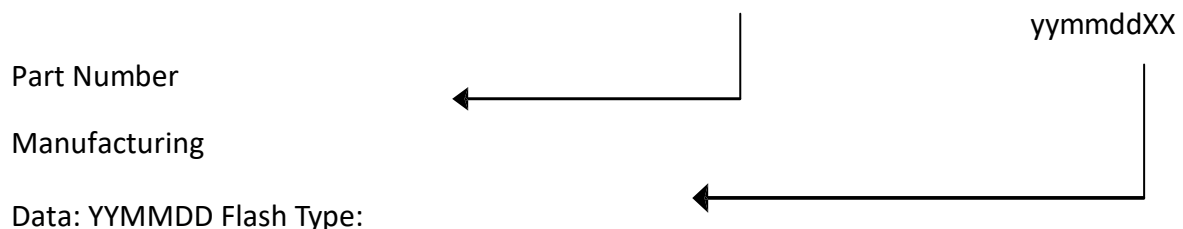

10. PARTNUMBER DECODER



HF3-25UFX⁸X⁹X¹⁰X¹¹X¹²X¹³X¹⁴X¹⁵X¹⁶X¹⁷

X ¹ X ² X ³	X ⁴ X ⁵	X ⁶ X ⁷	X ⁸ X ⁹ X ¹⁰ X ¹¹ X ¹²	X ¹³	X ¹⁴	X ¹⁵	X ¹⁶ X ¹⁷
HF3	25	UF	240GB 480GB 960GB 1920G 3840G	A: 3D TLC Standard (0°C ~ +70°C)	8	P	blank

