

# PPC-F H81 Series



## Intelligent Industrial Panel PC

### Features

- Support IEI iRIS-2400 IEI remote intelligent solution
- Scalable Intel® H81 chipset supports LGA1150 Intel® 4th generation Core™ i7/i5, Pentium® or Celeron® processor with up to 65W TDP
- Robust IP65 aluminum front bezel
- Aesthetic ultra-thin bezel for seamless panel mount installation
- Projected capacitive multi-touch
- Dual full-size PCIe Mini card expansion



### Specifications

Model		PPC-F15A	PPC-F17A
LCD	LCD Display	15" (4:3)	17" (5:4)
	Max. Resolution	1024 (W) x 768 (H)	1280 (W) x 1024 (H)
	Brightness (cd/m <sup>2</sup> )	450	350
	Contrast Ratio	800 : 1	800 : 1
	LCD Color	16.2M	16.7M
	Pixel Pitch (mm)	0.297 x 0.297	0.26 x 0.26
	Viewing Angle (H-V)	160° / 150°	170° / 160°
	Backlight MTBF (hrs)	70000	50000
Motherboard	SBC Model	FPPCMB-H81-R10	
	CPU	LGA1150 Intel® 4th generation Core™ i7/i5, Pentium® or Celeron® processor with up to 65W TDP	
	Chipset	Intel® H81	
	RAM	Support 2 x 204-pin 1066/1333/1600 MHz dual-channel DDR3 SO-DIMM slots (max. 16GB)	
Touch	Touchscreen & Controller	5-wire resistive single touch window, 3H/Penmount 9000 (Anti-glare Surface) 10-point Projected capacitive touch window, 6H/EETI EXC3188 (Anti-UV, Anti-glare Surface)	
Input Interfaces	I/O Ports & Switch	2 x RJ-45 LAN Port 2 x USB 3.2 Gen 1 (5Gb/s) 4 x USB 2.0 1 x HDMI output	4 x RS-232 1 x RS-422/485 1 x MIC-in 1 x Line-out
	Expansion	1 x Full-size/half-size PCIe Mini card (PCIe and USB signal) 1 x Full-size/half-size PCIe Mini card (PCIe, USB and mSATA signal)	
Wireless LAN		802.11 b/g/n (optional)	
Storage		1 x 2.5" HDD/SSD drive bay 1 x mSATA	
iRIS Remote Management Solution		iRIS-2400 (optional)	
Physical	Construction Material	Aluminum front cover and sheet metal rear cover	
	Mounting	Panel mount, rack mount, 100x100 VESA mount	
	Enclosure Color	Black C	
	Dimensions (mm)	303 x 378.5 x 68.7	341.4 x 408.4 x 73.8
	Cutout Dimensions (mm)	285.6 x 361.1	323 x 390
	Net/ Gross Weight (kg)	5.6/ 8.3	7.5/10.7
Environment	Operating Temperature (with air flow)	-10°C ~ 50°C	
	Storage Temperature	-20°C ~ 60°C	
	Humidity	10% to 95% (non-condensing)	
	IP Level	Front IP 65	
	Safety and EMC	CE & FCC certified	
Power Supply	AC Input	AC input ATX power supply - P/N: 63030-010220-100-RS - 220W power supply - Input: 90VAC-264VAC, 50/60Hz - Output (max.): 3.3V@10A, 5V@14A, 12V@14A, -12V@0.3A	
Power Consumption		80W	100W

## Ordering Information

Part No.	Description
15"	PPC-F15AA-H81i-P/4G/PC-R23 15" 450 cd/m <sup>2</sup> XGA Panel PC with Intel® H81 chipset, Intel® Pentium® Processor G3420 (3M Cache, 3.20 GHz), TDP 53W, 2GB RAM*2, support iRIS-2400, black color, PSU ACE-A622C, projective capacitive touch window with AG coating, R23
	PPC-F15AA-H81i-i5/4G/PC-R23 15" 450 cd/m <sup>2</sup> XGA Panel PC with Intel® H81 chipset, Core i5 Quad Core i5-4570S Processor (6M Cache, up to 3.60GHz), TDP 65W, 2GB RAM*2, support iRIS-2400, black color, PSU ACE-A622C, PCAP touch window with AG coating, R23
	PPC-F15AA-H81i-P/4G/R-R23 15" 450 cd/m <sup>2</sup> XGA Panel PC with Intel® H81 chipset, Intel® Pentium® Processor G3420 (3M Cache, 3.20 GHz), TDP 53W, 2GB RAM*2, support iRIS-2400, black color, PSU ACE-A622C, resistive touch window with AG coating, R23
	PPC-F15AA-H81i-i5/4G/R-R23 15" 450 cd/m <sup>2</sup> XGA Panel PC with Intel® H81 chipset, Core i5 Quad Core i5-4570S Processor (6M Cache, up to 3.60GHz), TDP 65W, 2GB RAM*2, support iRIS-2400, black color, PSU ACE-A622C, resistive touch window with AG coating, R23
17"	PPC-F17AA-H81i-P/4G/PC-R14 17" 350 cd/m <sup>2</sup> SXGA Panel PC with Intel® H81 chipset, Intel® Pentium® Processor G3420 (3M Cache, 3.20 GHz), TDP 53W, 2GB RAM*2, support iRIS-2400, black color, PSU ACE-A622C, projective capacitive touch window with AG coating, R14
	PPC-F17AA-H81i-i5/4G/PC-R14 17" 350 cd/m <sup>2</sup> SXGA Panel PC with Intel® H81 chipset, Core i5 Quad Core i5-4570S Processor (6M Cache, up to 3.60GHz), TDP 65W, 2GB RAM*2, support iRIS-2400, black color, PSU ACE-622C, projective capacitive touch window with AG coating, R14
	PPC-F17AA-H81i-P/4G/R-R14 17" 350 cd/m <sup>2</sup> SXGA Panel PC with Intel® H81 chipset, Intel® Pentium® Processor G3420 (3M Cache, 3.20 GHz), TDP 53W, 2GB RAM*2, support iRIS-2400, black color, PSU ACE-A622C, resistive touch window with AG coating, R14
	PPC-F17AA-H81i-i5/4G/R-R14 17" 350 cd/m <sup>2</sup> SXGA Panel PC with Intel® H81 chipset, Core i5 Quad Core i5-4570S Processor (6M Cache, up to 3.60 GHz), TDP 65W, 2GB RAM*2, support iRIS-2400, black color, PSU ACE-622C, resistive touch window with AG coating, R14

## Options

Item	PPC-F15A	PPC-F17A
Arm	ARM-31-RS	ARM-31-RS
Stand	STAND-A21 STAND-A19-RS STAND-C19-R10	STAND-C19-R10 STAND-A21-R10
Wall Mount Kit	WK-190MS-R10	
Panel Mount Kit	FPK-04-R10	
Rack Mount Kit	FRK15-R10	FRK17-R10
iRIS (IEI Remote Intelligent System) Kit	iRIS-2400-R10	

## Packing List

Item	Q'ty	Remark
Power Cord	1	Depends on shipping region
Screw Kit	1	

**PPC-F15A**  
Fully Integrated I/O

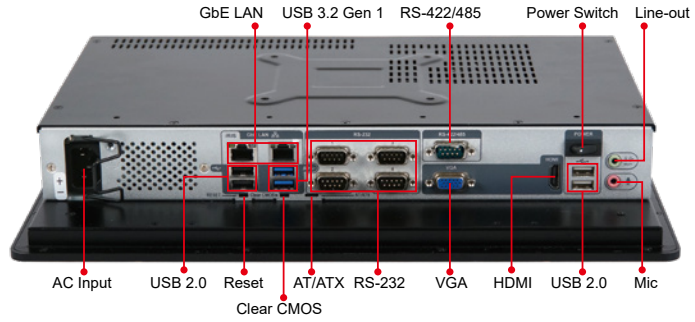

**PPC-F17A**  
Fully Integrated I/O

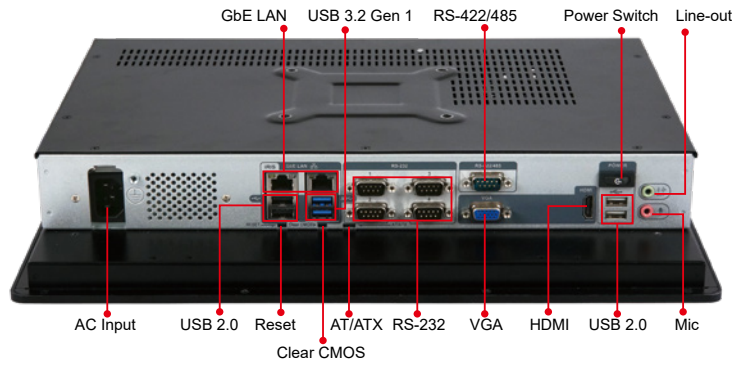

**PPC-F15A Dimensions**  
(Unit: mm)

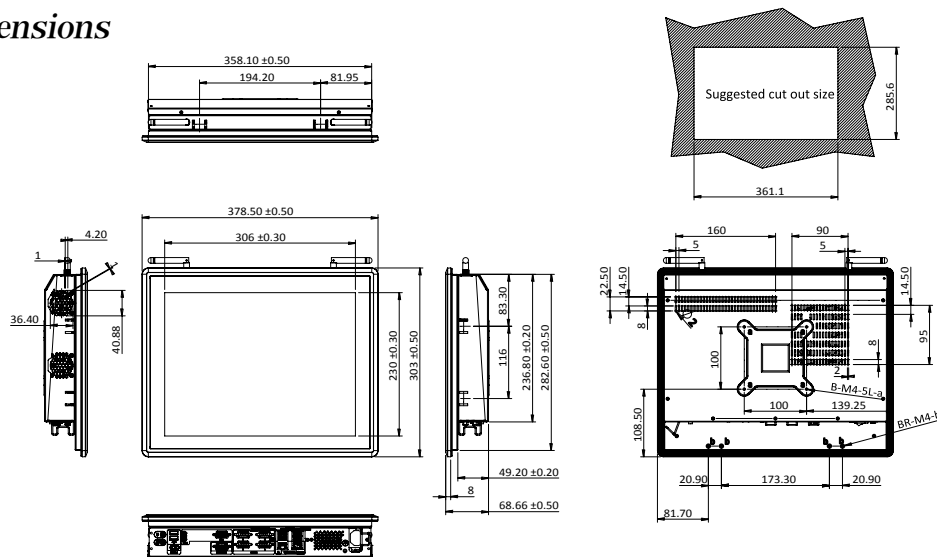

**PPC-F17A Dimensions**  
(Unit: mm)

